

Servo Motors

Series AKM



The synchronous servomotors from the AKM series are brushless, rotary current motors with three-phase windings for demanding servo applications. These motors have permanent magnets in the rotor. The neodymium magnet material and the low inertial moment contribute significantly to making these motors highly dynamic and allow them to have a very low cogging. The robust, compact motors with high power density are available in seven sizes and fine graduations, whereby customization is possible.

Motors are available with idling torques from 0.18 to 53 Nm and a peak torque of up to 143 Nm.

Motor and sensor cables in standard 5 m/10 m/15 m/20 m/25 m lengths are also available.

Standard Configuration:

Smooth wave, IP65 protection, 2-pin resolver, temperature sensors in the stator windings for monitoring the temperature, UL-conforming configuration

Options:

Fitted key, holding brake (AKM2-7), shaft seal (IP67), rotatable plug, various sensor systems

Technical Data

Motor	Motor - Data										Brake - Data			Drive	
	Motor standstill torque	Rated torque	Peak torque	Rated rotation speed	Rated power	Standstill current	Rated current	Peak current	Torque constant	Rotor inertial torque	Motor weight	Holding torque	Holding brake torque	Holding brake weight	Rated supply voltage 230 V
M_0 (Nm)	M_n (Nm)	M_{max} (Nm)	n_n (min ⁻¹)	P_n (kW)	I_0 (A)	I_n (A)	I_{max} (A)	KT (Nm/A)	J (kgcm ²)	m (kg)	M_{br} (Nm)	J_{br} (kgcm ²)	m_{br} (kg)		

AKM1

AKM11B	0.18	0.17	0.61	8000	0.14	1.16	1.06	4.6	0.16	0.017	0.35	-	-	-	X
AKM12C	0.31	0.28	1.08	8000	0.23	1.51	1.33	6	0.21	0.031	0.49	-	-	-	X
AKM13C	0.41	0.36	1.46	8000	0.30	1.48	1.29	5.9	0.28	0.045	0.63	-	-	-	X

AKM2

AKM21C	0.48	0.39	1.47	8000	0.32	1.58	1.30	6.3	0.30	0.11	0.82	1.42	0.011	0.27	X
AKM22C	0.84	0.78	2.73	3500	0.29	1.39	1.28	5.6	0.61	0.16	1.1	1.42	0.011	0.27	X
AKM22C	0.84	0.68	2.73	8000	0.57	1.39	1.11	5.6	0.61	0.16	1.1	1.42	0.011	0.27	X
AKM22E	0.87	0.70	2.76	8000	0.59	2.73	2.19	11	0.32	0.16	1.1	1.42	0.011	0.27	X
AKM23C	1.13	1.08	3.77	2500	0.28	1.41	1.35	5.6	0.80	0.22	1.38	1.42	0.011	0.27	X
AKM23C	1.13	0.99	3.77	5500	0.57	1.41	1.24	5.6	0.80	0.22	1.38	1.42	0.011	0.27	X
AKM23D	1.16	1.03	3.84	5000	0.54	2.19	1.98	8.8	0.52	0.22	1.38	1.42	0.011	0.27	X
AKM23D	1.16	0.92	3.84	8000	0.77	2.19	1.77	8.8	0.52	0.22	1.38	1.42	0.011	0.27	X
AKM23F	1.18	0.94	3.88	8000	0.79	4.31	3.48	17.2	0.27	0.22	1.38	1.42	0.011	0.27	X
AKM24C	1.38	1.32	4.67	2000	0.28	1.42	1.36	5.7	0.97	0.27	1.66	1.42	0.011	0.27	X
AKM24C	1.38	1.25	4.67	4500	0.59	1.42	1.29	5.7	0.97	0.27	1.66	1.42	0.011	0.27	X
AKM24D	1.41	1.29	4.76	4000	0.54	2.21	2.05	8.8	0.63	0.27	1.66	1.42	0.011	0.27	X
AKM24D	1.41	1.11	4.76	8000	0.93	2.21	1.76	8.8	0.63	0.27	1.66	1.42	0.011	0.27	X
AKM24F	1.42	1.12	4.82	8000	0.94	3.89	3.11	15.6	0.36	0.27	1.66	1.42	0.011	0.27	X

AKM3

AKM31C	1.15	1.12	3.88	2500	0.29	1.37	1.32	5.5	0.85	0.33	1.55	2.5	0.011	0.35	X
AKM31C	1.15	1.0	3.88	5000	0.52	1.37	1.18	5.5	0.85	0.33	1.55	2.5	0.011	0.35	X
AKM31E	1.20	0.95	4.0	6000	0.60	2.99	2.32	12	0.41	0.33	1.55	2.5	0.011	0.35	X
AKM32C	2.0	1.95	6.92	1500	0.31	1.44	1.39	5.8	1.40	0.59	2.23	2.5	0.011	0.35	X
AKM32C	2.0	1.86	6.92	3000	0.58	1.44	1.33	5.8	1.40	0.59	2.23	2.5	0.011	0.35	X

Technical Data

Motor	Motor - Data										Brake - Data			Drive		
	Motor standstill torque	Rated torque	Peak torque	Rated rotation speed	Rated power	Standstill current	Rated current	Peak current	Torque constant	Rotor inertial torque	Motor weight	Holding torque	Holding brake torque	Holding brake weight	Rated supply voltage 230 V	Rated supply voltage 400 V
	M_0 (Nm)	M_n (Nm)	M_{pmax} (Nm)	n_n (min ⁻¹)	P_n (kW)	I_0 (A)	IN (A)	I_{max} (A)	KT (Nm/A)	J (kgcm ²)	m (kg)	M_{br} (Nm)	J_{br} (kgcm ²)	m_{br} (kg)		
AKM32D	2.04	1.93	7.1	2500	0.51	2.23	2.10	8.9	0.92	0.59	2.23	2.5	0.011	0.35	X	
AKM32D	2.04	1.65	7.1	5500	0.95	2.23	1.79	8.9	0.92	0.59	2.23	2.5	0.011	0.35		X
AKM32E	2.04	1.87	7.11	3500	0.69	2.82	2.56	11.3	0.73	0.59	2.23	2.5	0.011	0.35	X	
AKM32E	2.04	1.41	7.11	7000	1.03	2.82	1.93	11.3	0.73	0.59	2.23	2.5	0.011	0.35		X
AKM32H	2.10	1.45	7.26	7000	1.06	5.50	3.72	22	0.39	0.59	2.23	2.5	0.011	0.35	X	
AKM33C	2.71	2.64	9.76	1000	0.28	1.47	1.42	5.9	1.86	0.85	2.9	2.5	0.011	0.35	X	
AKM33C	2.71	2.54	9.76	2000	0.53	1.47	1.37	5.9	1.86	0.85	2.9	2.5	0.011	0.35		X
AKM33E	2.79	2.62	9.96	2000	0.55	2.58	2.38	10.3	1.10	0.85	2.9	2.5	0.011	0.35	X	
AKM33E	2.79	2.34	9.96	4500	1.10	2.58	2.13	10.3	1.10	0.85	2.9	2.5	0.011	0.35		X
AKM33H	2.88	2.27	10.22	5500	1.31	5.62	4.37	22.5	0.52	0.85	2.9	2.5	0.011	0.35	X	

AKM4

AKM41C	1.95	1.88	6.12	1200	0.24	1.46	1.40	5.8	1.34	0.81	2.44	6	0.068	0.63	X	
AKM41C	1.95	1.77	6.12	3000	0.56	1.46	1.32	5.8	1.34	0.81	2.44	6	0.068	0.63		X
AKM41E	2.02	1.82	6.28	3000	0.57	2.85	2.56	11.4	0.71	0.81	2.44	6	0.068	0.63	X	
AKM41E	2.02	1.58	6.28	6000	0.99	2.85	2.23	11.4	0.71	0.81	2.44	6	0.068	0.63		X
AKM41H	2.06	1.62	6.36	6000	1.02	5.60	4.38	22.4	0.37	0.81	2.44	6	0.068	0.63	X	
AKM42C	3.35	3.10	11.3	1500	0.49	1.40	1.29	5.6	2.40	1.5	3.39	6	0.068	0.63		X
AKM42E	3.42	3.12	11.3	1800	0.59	2.74	2.48	11	1.26	1.5	3.39	6	0.068	0.63	X	
AKM42E	3.42	2.81	11.3	3500	1.03	2.74	2.23	11	1.26	1.5	3.39	6	0.068	0.63		X
AKM42G	3.53	2.90	11.5	3500	1.06	4.80	3.92	19.2	0.74	1.5	3.39	6	0.068	0.63	X	
AKM42G	3.53	2.35	11.5	6000	1.48	4.80	3.18	19.2	0.74	1.5	3.39	6	0.068	0.63		X
AKM42J	3.56	2.38	11.6	6000	1.5	8.4	5.53	33.6	0.43	1.5	3.39	6	0.068	0.63	X	
AKM43E	4.70	4.24	15.9	1500	0.67	2.76	2.47	11	1.72	2.1	4.35	6	0.068	0.63	X	
AKM43E	4.70	3.92	15.9	2500	1.03	2.76	2.28	11	1.72	2.1	4.35	6	0.068	0.63		X
AKM43G	4.80	4.00	16.1	2500	1.05	4.87	4.04	19.5	0.99	2.1	4.35	6	0.068	0.63	X	
AKM43G	4.80	3.01	16.1	5000	1.58	4.87	3.04	19.5	0.99	2.1	4.35	6	0.068	0.63		X

Technical Data

Motor	Motor - Data										Brake - Data			Drive		
	Motor standstill torque	Rated torque	Peak torque	Rated rotation speed	Rated power	Standstill current	Rated current	Peak current	Torque constant	Rotor inertial torque	Motor weight	Holding torque	Holding brake torque	Holding brake weight	Rated supply voltage 230 V	Rated supply voltage 400 V
	M_0 (Nm)	M_n (Nm)	M_{pmax} (Nm)	n_n (min ⁻¹)	P_n (kW)	I_0 (A)	IN (A)	I_{max} (A)	KT (Nm/A)	J (kgcm ²)	m (kg)	M_{br} (Nm)	J_{br} (kgcm ²)	m_{br} (kg)		
AKM43K	4.9	2.62	16.4	6000	1.65	9.6	5.04	38.4	0.52	2.1	4.35	6	0.068	0.63	X	
AKM44E	5.76	5.22	19.9	1200	0.66	2.90	2.55	11.4	2.04	2.7	5.30	6	0.068	0.63	X	
AKM44E	5.76	4.80	19.9	2000	1.01	2.90	2.35	11.4	2.04	2.7	5.30	6	0.068	0.63		X
AKM44G	5.88	4.90	20.3	2000	1.03	5.0	4.12	20	1.19	2.7	5.30	6	0.068	0.63	X	
AKM44G	5.88	3.76	20.3	4000	1.57	5.0	3.16	20	1.19	2.7	5.30	6	0.068	0.63		X
AKM44J	6.00	2.75	20.4	6000	1.73	8.80	3.99	35.2	0.69	2.7	5.30	6	0.068	0.63		X

AKM5

AKM51E	4.70	4.41	11.6	1200	0.55	2.75	2.56	8.2	1.72	3.4	4.2	14.5	0.173	1.1	X	
AKM51E	4.70	3.98	11.6	2500	1.04	2.75	2.31	8.2	1.72	3.4	4.2	14.5	0.173	1.1		X
AKM51G	4.75	4.02	11.7	2500	1.05	4.84	4.07	14.5	0.99	3.4	4.2	14.5	0.173	1.1	X	
AKM51G	4.75	2.62	11.7	5000	1.37	4.84	2.65	14.5	0.99	3.4	4.2	14.5	0.173	1.1		X
AKM51H	4.79	3.87	11.7	3000	1.22	6	4.84	18	0.8	3.4	4.2	14.5	0.173	1.1	X	
AKM51H	4.79	1.95	11.7	6000	1.23	6	2.44	18	0.8	3.4	4.2	14.5	0.173	1.1		X
AKM51K	4.9	2.35	11.9	5500	1.35	9.4	4.52	28.2	0.52	3.4	4.2	14.5	0.173	1.1	X	
AKM52E	8.34	7.61	21.3	1500	1.20	2.99	2.73	9	2.79	6.2	5.8	14.5	0.173	1.1		X
AKM52G	8.43	7.69	21.5	1500	1.21	4.72	4.30	14.2	1.79	6.2	5.8	14.5	0.173	1.1	X	
AKM52G	8.43	7.06	21.5	2500	1.85	4.72	3.94	14.2	1.79	6.2	5.8	14.5	0.173	1.1		X
AKM52H	8.48	7.53	21.6	1800	1.42	5.9	5.22	17.7	1.44	6.2	5.8	14.5	0.173	1.1	X	
AKM52H	8.48	6.26	21.6	3500	2.3	5.9	4.35	17.7	1.44	6.2	5.8	14.5	0.173	1.1		X
AKM52K	8.60	3.90	21.9	5500	2.25	9.3	4.19	27.9	0.93	6.2	5.8	14.5	0.173	1.1		X
AKM52L	8.67	6.40	30.1	3500	2.35	11.6	8.53	58	0.75	6.2	5.8	14.5	0.173	1.1	X	
AKM52L	8.67	3.27	30.1	6000	2.06	11.6	4.36	58	0.75	6.2	5.8	14.5	0.173	1.1		X
AKM52M	8.6	5.2	21.9	4500	2.45	13.1	7.88	39.4	0.66	6.2	5.8	14.5	0.173	1.1	X	
AKM53G	11.4	10.7	29.7	1000	1.12	4.77	4.48	14.3	2.39	9.1	7.4	14.5	0.173	1.1	X	
AKM53G	11.4	9.85	29.7	2000	2.06	4.77	4.12	14.3	2.39	9.1	7.4	14.5	0.173	1.1		X
AKM53H	11.5	8.83	30.0	3000	2.77	6.6	5.05	19.8	1.75	9.1	7.4	14.5	0.173	1.1		X



Technical Data

Motor	Motor - Data										Brake - Data			Drive		
	Motor standstill torque	Rated torque	Peak torque	Rated rotation speed	Rated power	Standstill current	Rated current	Peak current	Torque constant	Rotor inertial torque	Motor weight	Holding torque	Holding brake torque	Holding brake weight	Rated supply voltage 230 V	Rated supply voltage 400 V
	M_0 (Nm)	M_n (Nm)	M_{pmax} (Nm)	n_n (min ⁻¹)	P_n (kW)	I_0 (A)	I_n (A)	I_{max} (A)	KT (Nm/A)	J (kgcm ²)	m (kg)	M_{br} (Nm)	J_{br} (kgcm ²)	m_{br} (kg)		
AKM53K	11.6	7.65	30.3	4000	3.20	9.4	6.17	28.2	1.24	9.1	7.4	14.5	0.173	1.1		X
AKM53M	11.4	8.72	29.7	3000	2.74	13.4	10.26	40.2	0.85	9.1	7.4	14.5	0.173	1.1		X
AKM53P	11.4	5.88	29.8	5000	3.08	19.1	9.8	57.4	0.6	9.1	7.4	14.5	0.173	1.1		X
AKM54G	14.3	12.9	38.0	1500	2.03	5.0	4.48	15	2.88	12	9	14.5	0.173	1.1		X
AKM54H	14.2	12.6	37.5	1500	2.38	5.5	4.9	16.5	2.57	12	9	14.5	0.173	1.1		X
AKM54K	14.4	10.0	38.4	3500	3.68	9.7	6.73	29.2	1.50	12	9	14.5	0.173	1.1		X
AKM54L	14.1	8.13	37.5	4500	3.83	12.5	7.19	37.5	1.13	12	9	14.5	0.173	1.1		X
AKM54N	14.1	9.85	37.6	3500	3.61	17.8	12.31	53.4	0.8	12	9	14.5	0.173	1.1	X	

AKM6

AKM62G	11.9	10.4	29.7	1800	1.96	4.9	4.33	14.7	2.47	17	8.9	25	0.61	2		X
AKM62K	12.2	9.00	30.2	3500	3.30	9.6	7.04	28.8	1.28	17	8.9	25	0.61	2		X
AKM62M	12.2	5.70	30.2	6000	3.58	13.4	6.31	40.3	0.91	17	8.9	25	0.61	2		X
AKM62P	12.3	8.1	30.3	4500	3.82	18.8	12.27	56.4	0.66	17	8.9	25	0.61	2	X	
AKM63G	16.5	14.9	42.1	1200	1.87	4.5	4.14	13.5	3.70	24	11.1	25	0.61	2		X
AKM63K	16.8	12.9	42.6	3000	4.05	9.9	7.54	29.7	1.71	24	11.1	25	0.61	2		X
AKM63M	17.0	11.3	43.0	4000	4.73	13.8	9.11	41.4	1.24	24	11.1	25	0.61	2		X
AKM63N	17.0	9.60	43.0	5000	5.03	17.4	9.80	52.2	0.98	24	11.1	25	0.61	2		X
AKM64K	20.8	17.2	53.5	2000	3.60	9.2	7.54	27.6	2.28	32	13.3	25	0.61	2		X
AKM64L	21.0	15.6	54.1	3000	4.90	12.8	9.40	38.4	1.66	32	13.3	25	0.61	2		X
AKM64P	20.4	11.9	52.9	4500	5.61	18.6	10.82	55.9	1.10	32	13.3	25	0.61	2		X
AKM64Q	20	15.3	53.2	3000	4.81	20.7	15.3	62.1	1	32	13.3	25	0.61	2	X	
AKM64Q	20	10.7	53.2	5000	6.45	20.7	10.7	62.1	1	32	13.3	25	0.61	2		X
AKM65K	24.8	20.2	64.5	2000	4.23	9.8	7.95	29.1	2.54	40	15.4	25	0.61	2		X
AKM65M	25.0	19.2	65.2	2500	5.03	13.6	10.38	40.8	1.85	40	15.4	25	0.61	2		X
AKM65N	24.3	16.0	63.7	3500	5.86	17.8	11.59	53.4	1.38	40	15.4	25	0.61	2		X

Technical Data

Motor	Motor - Data										Brake - Data			Drive		
	Motor standstill torque	Rated torque	Peak torque	Rated rotation speed	Rated power	Standstill current	Rated current	Peak current	Torque constant	Rotor inertial torque	Motor weight	Holding torque	Holding brake torque	Holding brake weight	Rated supply voltage 230 V	Rated supply voltage 400 V
	M_0 (Nm)	M_n (Nm)	M_{pmax} (Nm)	n_n (min ⁻¹)	P_n (kW)	I_0 (A)	I_n (A)	I_{max} (A)	KT (Nm/A)	J (kgcm ²)	m (kg)	M_{br} (Nm)	J_{br} (kgcm ²)	m_{br} (kg)		
AKM65P	24.5	19.1	64.1	2400	4.8	19.8	14.69	59.3	1.3	40	15.4	25	0.61	2	X	
AKM65P	24.5	14.9	64.1	4000	6.24	19.8	11.46	59.3	1.3	40	15.4	25	0.61	2		X

AKM7

AKM72K	29.7	25.1	79.4	1500	3.94	9.3	7.77	27.9	3.23	65	19.7	53	1.64	2.1		X
AKM72M	30.0	23.6	79.8	2000	4.94	13.0	10.13	39.0	2.33	65	19.7	53	1.64	2.1		X
AKM72P	29.4	20.1	78.5	3000	6.31	18.7	12.72	56.1	1.58	65	19.7	53	1.64	2.1		X
AKM72Q	29.5	23.2	78.4	2000	4.86	23.5	17.85	70.5	1.3	65	19.7	53	1.64	2.1	X	
AKM72Q	29.5	16.3	78.4	4000	6.83	23.5	12.54	70.5	1.3	65	19.7	53	1.64	2.1		X
AKM73M	42.0	33.8	112	1500	5.31	13.6	10.90	40.8	3.10	92	26.7	53	1.64	2.1		X
AKM73P	41.6	28.5	111	2400	7.16	19.5	13.38	58.6	2.13	92	26.7	53	1.64	2.1		X
AKM73Q	41.5	33.4	111	1500	5.25	24.5	19.65	73.5	1.7	92	26.7	53	1.64	2.1	X	
AKM73Q	41.5	25.2	111	3000	7.92	24.5	14.82	73.5	1.7	92	26.7	53	1.64	2.1		X
AKM74L	53.0	43.5	143	1200	5.47	12.9	10.99	38.7	4.14	120	33.6	53	1.64	2.1		X
AKM74P	52.5	39.6	142	1800	7.46	18.5	13.24	55.5	2.84	120	33.6	53	1.64	2.1		X
AKM74Q	52.2	41.9	141	1300	5.71	26.1	20.95	78.3	2	120	33.6	53	1.64	2.1	X	
AKM74Q	52.2	31.5	141	2500	8.25	26.1	15.75	78.3	2	120	33.6	53	1.64	2.1		X

Servo Motors

Series AKM Low Voltage

Technical Data

Motor		Motor - Data									Drive		
	Motor standstill torque	Rated torque	Peak torque	Rated rotation speed	Rated power	Standstill current	Rated current	Peak current	Torque constant	Rotor inertial torque	Motor weight	Rated supply voltage 24 V	Rated supply voltage 48 V
	M_0 (Nm)	M_n (Nm)	M_{peak} (Nm)	n_n (min ⁻¹)	P_n (kW)	I_0 (A)	IN (A)	I_{max} (A)	KT (Nm/A)	J (kgcm ²)	m (kg)		

AKM 1 Low Voltage

AKM11F	0.18	0.18	0.59	1000	0.02	3.87	3.95	15.5	0.0456	0.017	0.35	X	
AKM11F	0.18	0.17	0.59	5000	0.09	3.87	3.73	15.5	0.0456	0.017	0.35		X
AKM12E	0.31	0.30	1.05	1500	0.05	2.73	2.67	10.9	0.1125	0.031	0.49		X

AKM 2 Low Voltage

AKM21J	0.43	0.42	1.38	1200	0.05	7.3	6.93	28.5	0.0606	0.11	0.82	X	
AKM21J	0.43	0.39	1.38	4500	0.18	7.3	6.44	28.5	0.0606	0.11	0.82		X
AKM22H	0.88	0.85	2.80	1500	0.13	5.41	5.21	21.6	0.1632	0.16	1.10		X

AKM 3 Low Voltage

AKM31K	1.25	1.23	4.12	2000	0.26	9.1	8.82	36.4	0.1395	0.33	1.55		X
--------	------	------	------	------	------	-----	------	------	--------	------	------	--	---

Notes

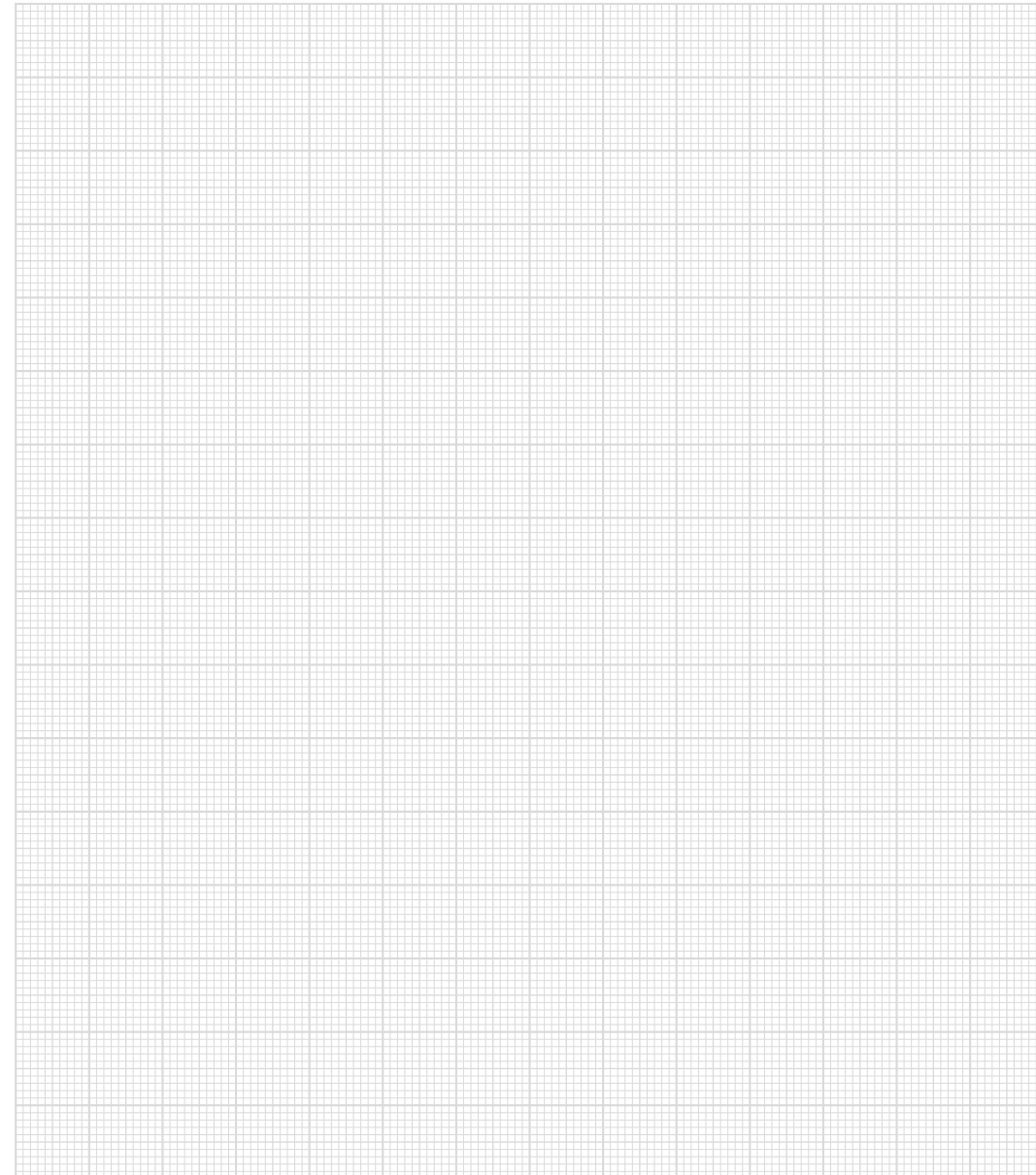

Servo Motors

Mechanical Dimensions

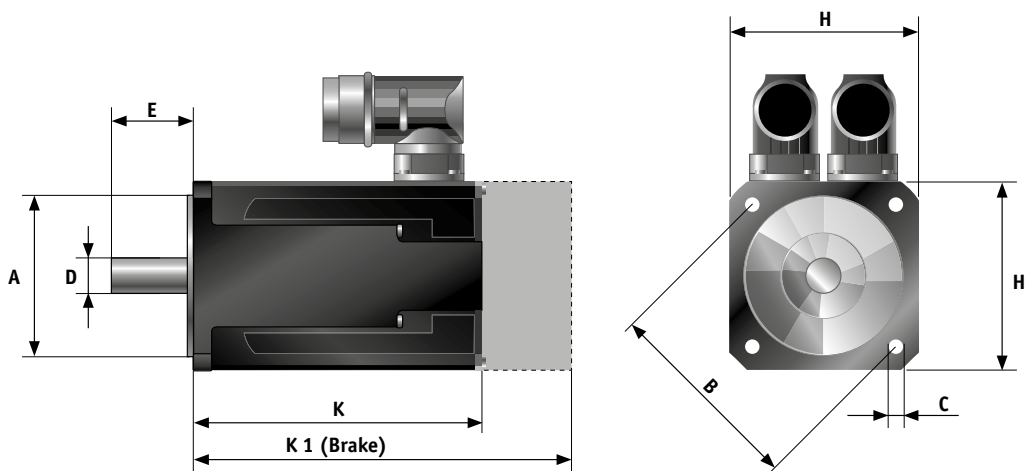

Mechanical Dimensions

Motor type	A	B	C	D	E	H	K (Resolver)	K1 (Resolver)	K (Hiperface)	K1 (Hiperface)
AKM1										
AKM11	30h7	46	4.3	8h7	25	40	69.6	106.6	79	116
AKM11F	30h7	46	4.3	8h7	25	40	69.6	-	79	-
AKM12	30h7	46	4.3	8h7	25	40	88.6	125.6	98	135
AKM12E	30h7	46	4.3	8h7	25	40	88.6	-	98	-
AKM13	30h7	46	4.3	8h7	25	40	107.6	144.6	117	154
AKM1 with Y-TEC plug										
AKM11	30h7	46	4.3	8h7	25	40	79	116	87.5	124.5
AKM11F	30h7	46	4.3	8h7	25	40	79	-	87.5	-
AKM12	30h7	46	4.3	8h7	25	40	98	135	107.5	144.5
AKM12E	30h7	46	4.3	8h7	25	40	98	-	107.5	-
AKM13	30h7	46	4.3	8h7	25	40	117	154	126.5	163.5

Mechanical Dimensions

Motor type	A	B	C	D	E	H	K (Resolver)	K1 (Resolver)	K (Hiperface)	K1 (Hiperface)
AKM2										
AKM21	40j6	63	4.8	9k6	20	58	95.4	129.5	113.4	147.1
AKM21J	40j6	63	4.8	9k6	20	58	95.4	-	113.4	-
AKM22	40j6	63	4.8	9k6	20	58	114.4	148.5	132.4	166.1
AKM22H	40j6	63	4.8	9k6	20	58	114.4	-	132.4	-
AKM23	40j6	63	4.8	9k6	20	58	133.4	167.5	151.4	185.1
AKM24	40j6	63	4.8	9k6	20	58	152.4	186.5	170.4	204.1
AKM3										
AKM31	60j6	75	5.8	14k6	30	70	109.8	141.3	125.3	159.3
AKM31K	60j6	75	5.8	14k6	30	70	109.8	-	125.3	-
AKM32	60j6	75	5.8	14k6	30	70	140.8	172.3	156.3	190.3
AKM33	60j6	75	5.8	14k6	30	70	171.8	203.3	187.3	221.3
AKM4										
AKM41	80j6	100	7	19k6	40	84	118.8	152.3	136.8	170.3
AKM42	80j6	100	7	19k6	40	84	147.8	181.3	165.8	199.3
AKM43	80j6	100	7	19k6	40	84	176.8	210.3	194.8	228.3
AKM44	80j6	100	7	19k6	40	84	205.8	239.3	223.8	257.3
AKM5										
AKM51	110j6	130	9	24k6	50	108	127.5	172.5	146	189
AKM52	110j6	130	9	24k6	50	108	158.5	203.5	177	220
AKM53	110j6	130	9	24k6	50	108	189.5	234.5	208	251
AKM54	110j6	130	9	24k6	50	108	220.5	265.5	239	282
AKM6										
AKM62	130j6	165	11	32k6	58	138	153.7	200.7	172.2	219.7
AKM63	130j6	165	11	32k6	58	138	178.7	225.7	197.2	244.7
AKM64	130j6	165	11	32k6	58	138	203.7	250.7	222.2	269.7
AKM65	130j6	165	11	32k6	58	138	228.7	275.7	247.2	294.7
AKM7										
AKM72	180j6	215	13.5	38k6	80	188	192.5	234.5	201.7	253.3
AKM73	180j6	215	13.5	38k6	80	188	226.5	268.8	235.7	287.3
AKM74	180j6	215	13.5	38k6	80	188	260.5	302.5	269.7	321.3

Order Code

AKM 4 4 J-AN C N GB B0

Flange size: 1 40 mm 2 58 mm 3 70 mm 4 84 mm 5 108 mm 6 138 mm 7 188 mm	Shaft sealing: B0 standard B1 with shaft sealing xx special
Rotor length: 1 2 3 4 5	Feedback unit: DA EnDat 2.1 (AKM2...7) ENC-1113/1313 (Single Turn opt.) DB EnDat 2.1 (AKM2...7) EQN-1125/1325 (Multi Turn opt.) LA EnDat 2.1 (AKM2...7) ECI-1118/1319 (Single Turn ind.) LB EnDat 2.1 (AKM2...7) EQI-1130/1331 (Multi Turn ind.) GA Hiperface SKS36 (Single Turn opt.) GB Hiperface (AKM2...7) SKM36 (Multi Turn opt.) GD Hiperface (AKM1) SEL34 (Multi Turn kap.) R resolver (Single Turn ind.) S special
Winding type: A ... Z S special	Brake: 2 24 V holding brake N without brake S special
Flange: A IEC B NEMA C alternative IEC standard D other standard G alternative IEC standard H alternative IEC standard R IEC with tolerance R	Connections: B angled connector, rotatable (AKM2) C 0.5 m shielded cable with IP65 connector, (AKM1/2) angled connector, rotatable (AKM3...7) Y y-tec plug IP65 (AKM1) S special
Shaft: C feather key groove K open feather key groove N smooth shaft S special	

Example Servo Motor AKM 4 4 J-AN C N GB B0:
 Motortype AKM 44J, flange according to IEC standard, smooth shaft, rotatable connectors, without brake, multiturn encoder SKM36

Detailed motor data can be found in the technical documentation.

Notes

