

# ET 0710

Built-In Terminal

## INSTRUCTION MANUAL

Article number: 01-235-0710-E

Date of creation: 20.10.2025

Version date: 20.03.2026

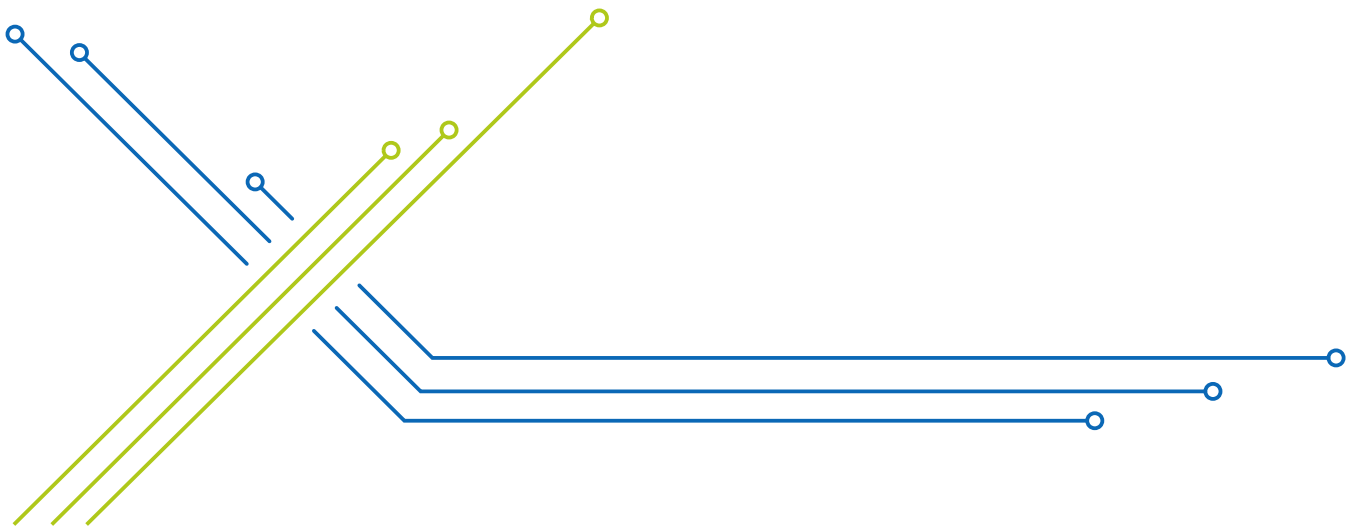

**Publisher:**

SIGMATEK GmbH & Co KG  
A-5112 Lamprechtshausen  
Tel.: +43/6274/4321  
Fax: +43/6274/4321-18

Email: [office@sigmatek.at](mailto:office@sigmatek.at)

[www.sigmatek-automation.com](http://www.sigmatek-automation.com)

All rights reserved. No part of this work may be reproduced, edited using an electronic system, duplicated or distributed in any form (print, photocopy, microfilm or in any other process) without express permission.

We reserve the right to make changes in the content without notice. SIGMATEK GmbH & Co KG is not responsible for technical or printing errors in this handbook and assumes no responsibility for damages that occur through its use.

## Built-In Terminal

ET 0710

The ET 0710 is an intelligent panel for visualizing, operating and monitoring automated processes. Process diagnostics is therewith simplified.

A projective capacitive touch screen serves as the input medium for process data and parameters. The output is shown on a 7" IPS color display.

With the LASAL visualization tool, graphics can be created on the PC, then stored and displayed on the handheld operating panel.

The available interfaces can be used to exchange process data or configure the multi-touch terminal.

The operating system, application and application data are stored on the internal storage medium.



## Table of Contents

<b>1 Introduction</b>	<b>5</b>
1.1 Target Group/Purpose of this Operating Manual	5
1.2 Important Reference Documentation	5
1.3 Contents of Delivery	5
<b>2 Basic Safety Directives</b>	<b>6</b>
2.1 Symbols Used	6
2.2 Disclaimer	7
2.3 General Safety Directives	7
2.4 Software/Training	8
<b>3 Standards and Directives</b>	<b>9</b>
3.1 Directives	9
3.1.1 EU Declaration of Conformity	9
<b>4 Type Plate</b>	<b>10</b>
<b>5 Technical Data</b>	<b>11</b>
5.1 Performance Data	11
5.2 Electrical Requirements	12
5.3 Temperature Sensor	12
5.4 Display	13
5.5 Control Unit	14
5.6 Minimum Distance between Operating Elements for Multi-touch Applications	15
5.7 Input	15
5.8 Environmental Conditions	16
5.9 Miscellaneous	16
<b>6 Interfaces</b>	<b>17</b>
6.1 Rear Connectors	17
6.1.1 X1: CAN Bus, X2: Supply (2x 5-pin Phoenix RM 3.5)	18
6.1.2 X3: RS485 (COM2) (3-pin Phoenix RM 3,5)	18
6.1.3 X4: Ethernet (10/100 Mbit/s) (RJ45)	19
6.1.4 X5: USB 2.0, Host (Type A)	19
6.1.5 X6: microSD	20
6.1.6 X7: USB 2.0, Host & Device (Type C)	20

6.1.7 X8: CAN, Supply (Molex Picoblade RM1.25)	21
6.2 Applicable Connectors	21
6.3 Status Display LEDs	22
<b>7 Mechanical Dimensions</b>	<b>23</b>
<b>8 Assembly/Installation</b>	<b>24</b>
8.1 Check Contents of Delivery	24
8.2 Installation	24
8.3 Mounting Instructions	24
8.3.1 Required Cutout for Mounting the Terminal	25
8.3.2 Mounting Position	25
8.3.3 Minimum Distance Installation	26
<b>9 Wiring</b>	<b>27</b>
9.1 Grounding	27
9.2 Shielding	27
9.3 ESD Protection	27
9.4 USB Interface	27
9.5 CAN Bus	28
9.5.1 CAN Bus Station Number	28
9.5.2 Number of CAN Bus Participants	28
9.5.3 CAN Bus Data Transfer Rate	28
9.5.4 CAN Bus Termination	29
9.6 RS485	29
<b>10 Process Diagram</b>	<b>30</b>
<b>11 Status and Error Messages</b>	<b>31</b>
<b>12 Transport/Storage</b>	<b>39</b>
<b>13 Storage</b>	<b>40</b>
<b>14 Maintenance</b>	<b>41</b>
14.1 Cleaning and Disinfecting the Touch Screen	41
14.2 Service	41
14.2.1 Calibrating the Touch Screen	41
14.3 Repair	42
<b>15 Buffer Battery</b>	<b>43</b>

15.1 Data Retention Battery Change .....	43
<b>16 Display „Burn-In“ Effect .....</b>	<b>44</b>
16.1 Screen Saver .....	44
<b>17 Disposal .....</b>	<b>45</b>
<b>18 Accessories .....</b>	<b>46</b>
18.1 Touch Pen .....	46
18.2 Battery .....	46
18.3 microSD Card .....	46
<b>19 Application Information .....</b>	<b>47</b>
19.1 Storage Media .....	47
19.1.1 Create Boot Media (Make Bootdisk) .....	47
19.1.2 Lifetime Calculation (Flash Media Lifetime Calculation) .....	48

# 1 Introduction

## 1.1 Target Group/Purpose of this Operating Manual

This operating manual contains all information required for the operation of the product.

This operating manual is intended for:

- Project planners
- Technicians
- Commissioning engineers
- Machine operators
- Maintenance/test technicians

General knowledge of automation technology is required.

Further help and training information, as well as the appropriate accessories can be found on our website [www.sigmatek-automation.com](http://www.sigmatek-automation.com).

Our support team is happily available to answer your questions.  
Please see our website for our hotline number and business hours.

## 1.2 Important Reference Documentation

- HW IP Address Settings

This and additional documents can be downloaded from our website or obtained through support.

## 1.3 Contents of Delivery

1x ET 0710

4x angle bracket

## 2 Basic Safety Directives

### 2.1 Symbols Used

The following symbols are used in the operator documentation for warning and danger messages, as well as informational notes.

#### DANGER



**Danger** indicates that death or serious injury **will occur**, if the specified measures are not taken.

→ To avoid death or serious injuries, observe all guidelines.

**Danger** indique une situation dangereuse qui, faute de prendre les mesures adéquates, **entraînera** des blessures graves, voire mortelles.

→ Respectez toutes les consignes pour éviter des blessures graves, voire mortelles.

#### WARNING



**Warning** indicates that death or serious injury **can** occur, if the specified measures are not taken.

→ To avoid death or serious injuries, observe all guidelines.

**Avertissement** d'une situation dangereuse qui, faute de prendre les mesures adéquates, **entraînera** des blessures graves, voire mortelles.

→ Respectez toutes les consignes pour éviter des blessures graves, voire mortelles.

#### CAUTION



**Caution** indicates that moderate to slight injury **can** occur, if the specified measures are not taken.

→ To avoid moderate to slight injuries, observe all guidelines.

**Attention** indique une situation dangereuse qui, faute de prendre les mesures adéquates, **peut** entraîner des blessures assez graves ou légères.

→ Respectez toutes les consignes pour éviter des blessures graves, voire mortelles.

#### CAUTION



Danger for ESD-sensitive components.

Les signes de danger pour les composants sensibles aux décharges électrostatiques.

#### INFORMATION



#### INFORMATION

→ Provides important information on the product, handling or relevant sections of the documentation, which require particular attention.

## 2.2 Disclaimer

The contents of this operating manual were prepared with the greatest care. However, deviations cannot be ruled out. This operating manual is regularly checked and required corrections are included in the subsequent versions. The machine manufacturer is responsible for the proper assembly, as well as device configuration. The machine operator is responsible for safe handling, as well as proper operation.

The current operating manual can be found on our website. If necessary, contact our support.

Subject to technical changes, which improve the performance of the devices. The following operating manual is purely a product description. It does not guarantee properties under the warranty.

Please thoroughly read the corresponding documents and this operating manual before handling a product.

**SIGMATEK GmbH & Co KG is not liable for damages caused through, non-compliance with these instructions or applicable regulations.**

## 2.3 General Safety Directives

The Safety Directives in the other sections of this operating manual must be observed. These instructions are visually emphasized by symbols.

According to EU Directives, the operating manual is a component of a product. This operating manual must therefore be accessible in the vicinity of the machine since it contains important instructions. This operating manual should be included in the sale, rental or transfer of the product, or its online availability indicated.

Regarding the requirements for Safety and health connected to the use of machines, the manufacturer must perform a risk assessment in accordance with machine directives 2006/42/EG before introducing a machine to the market.

### INFORMATION



Operate the unit with devices and accessories approved by SIGMATEK only.

**CAUTION**

Handle the device with care and do not drop or let fall.  
Prevent foreign bodies and fluids from entering the device.  
The device must not be opened!

Manipulez l'appareil avec précaution et ne le laissez pas tomber.  
Empêchez les corps étrangers et les liquides de pénétrer dans l'appareil.  
L'appareil ne doit pas être ouvert!

If the device does not function as intended or has damage that could pose a danger, it must be replaced!

En cas de fonctionnement non conforme ou de dommages pouvant entraîner des risques, l'appareil doit être remplacé !

For your own safety and that of others, compliance with the environmental conditions is essential.

Pour votre propre sécurité et celle des autres, le respect des conditions environnementales est essentiel.

**INFORMATION**

Hardware and software features (application-specific data) can be found in chapter 19 Application Information.

## 2.4 Software/Training

The application is created with the software LASAL CLASS 2 and LASAL SCREEN Editor / VISUDesigner (HTML5).

Training for the LASAL development environment, with which the product can be configured, is provided. Information on our training schedule can be found on our website.

## 3 Standards and Directives

### 3.1 Directives

The product was constructed in compliance with the following European Union directives and tested for conformity.

#### 3.1.1 EU Declaration of Conformity



---

#### EU Declaration of Conformity

The product ET 0710 conforms to the following European directives:

- 2014/30/EU Electromagnetic Compatibility (EMC Directive)
- 2011/65/EU “Restricted use of certain hazardous substances in electrical and electronic equipment” (RoHS Directive)

The EU Conformity Declarations are provided on the SIGMATEK website. They can be found in the download area of the respective product.

---

## 4 Type Plate

The type plate provides information about the product's features. The type plate shown here is only an example.

	HW: X.XX    SW: XX.XX.XXX Safety Version: SXX.XX.XX
Serial No.	SIGMATEK GMBH & CO KG Sigmatekstrasse 1 A-5112 LAMPRECHTSHAUSEN
Article Number	Product Name    Short Name

HW: Hardware version

FS: Safety version number

FW: Firmware version

LD: Logic device version

QR-Code: Serial number

## 5 Technical Data

### 5.1 Performance Data

Processor	EDGE3-Technology
Processor cores	4 <sup>1)</sup>
Internal program and data memory (RAM)	2-Gbyte (LPDDR4)
Internal remnant data memory	128-kByte FRAM
Internal storage device	8-Gbyte microSD (16-Gbyte 2:1 formatted ~60k P/E cycles) <sup>2)</sup>
Optional memory expansion	no
Graphic	integrated in EDGE processor
Interfaces	1x Ethernet (10/100) 1x USB 2.0 Host Type A 1x USB 2.0 Host/Device Type C 1x RS485 1x CAN 1x microSD card holder (SD 3.0)
Internal interface connections and devices	no
Operating components	no
Signal generator	no
Display Resolution	7" IPS color display WSVGA 1024 x 600 pixels
Operating field	Touch screen (multi-touch, projective capacitive)
Status LEDs	yes, 2-color front LED (green/red) Status LEDs (green/yellow)
Real-time clock	yes (battery buffered)
Cooling	passive

<sup>1)</sup> Attention: When programming on multi-core CPUs (with LASAL), particular focus must be placed on thread security!

<sup>2)</sup> The internal storage medium is formatted in the specified ratio to increase its lifespan. Changing the format to the full storage medium size is not permitted and will result in a significant reduction in lifespan.

## 5.2 Electrical Requirements

Supply voltage	+24 V DC $\pm 20\%$ (SELV/PELV) UL: NEC Class 2	
Protection class	III	
Current consumption of power supply (+24 V)	typically 320 mA (with no external devices connected)	maximum 530 mA (with external devices connected)
Inrush current without current-limiting supply	60,5 A for 41 $\mu$ s	
Inrush current with 24 V/10 A fixed voltage supply	1 A for 100 ms	

### INFORMATION



For USA and Canada:

The supply must be limited to:

- a) max. 5 A at voltages from 0-20 V DC, or
- b) 100 W at voltages from 20-60 V DC

The limiting component (e.g. transformer, power supply or fuse) must be certified by an NRTL (Nationally Recognized Testing Laboratory).

## 5.3 Temperature Sensor

Two temperature sensors are installed in ET 0710. These can be read out via the software.

- Core temperature CPU core (max. 105 °C)
- Ambient temperature CPU board (max. 80 °C)

## 5.4 Display

Type	7" IPS color display
Resolution	WSVGA 1024 x 600 pixels
Color depth	24-Bit RGB
LCD mode	normally black <sup>1)</sup>
LCD Polarizer	transmissive <sup>2)</sup>
Pixel size	0.1506 x 0.1432 mm
Active range	154.21 x 85.92 mm
Backlighting	LED, adjustable
Contrast ratio	typically 800:1
Brightness	typically 350 cd/m <sup>2</sup>
Angle CR ≥ 10	left, right, top, bottom typically 85° <sup>3)</sup>
Life span	By compliance with the ambient conditions, the brightness of the display sinks after 30,000 operating hours to 50 % of the original brightness.

Due to the manufacturing process, individual pixel errors cannot be excluded to 100 % and therefore do not constitute a reduction in quality.

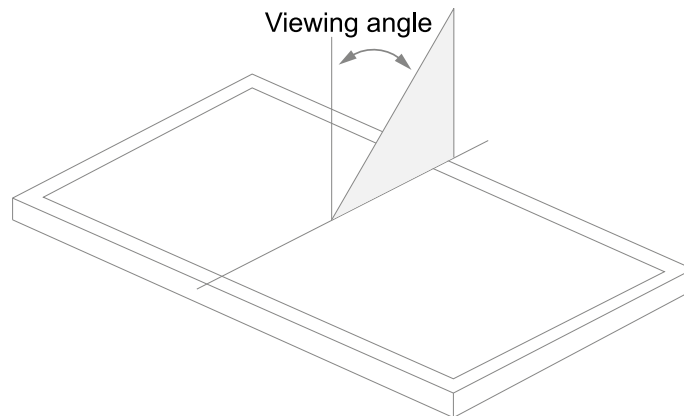

1) If there is no display data, the display remains black when the backlighting is on.

2) Display technology, with which display backlighting is used.

3) The viewing angle is measured from the normal to the display surface.

## 5.5 Control Unit

Operating field	Touch screen (multi-touch, projective capacitive)
Maximum number of fingers	5
The operation with thin gloves	yes
SIGMATEK Touch pen (passive)	yes
Handwriting recognition	no
Ball of the thumb recognition	no
Water spray recognition <sup>1)</sup>	yes
Water detection <sup>2)</sup>	no
Cleaning	see chapter 14.1 Cleaning and Disinfecting the Touch Screen

### INFORMATION



The device must always be grounded or with cable-connected devices, the mass must be connected correctly to ensure stable function of the touch screen. The touch function may still have to be individually adapted to the respective environmental conditions.

1) Detects individual water droplets on the touch screen and remains operable.

2) Detects a large amount of water on the touch screen and deactivates it.

## 5.6 Minimum Distance between Operating Elements for Multi-touch Applications

To guarantee smooth operation with multi-touch applications, buttons and control elements that should be operated at the same time must have a realistic minimum clearance.

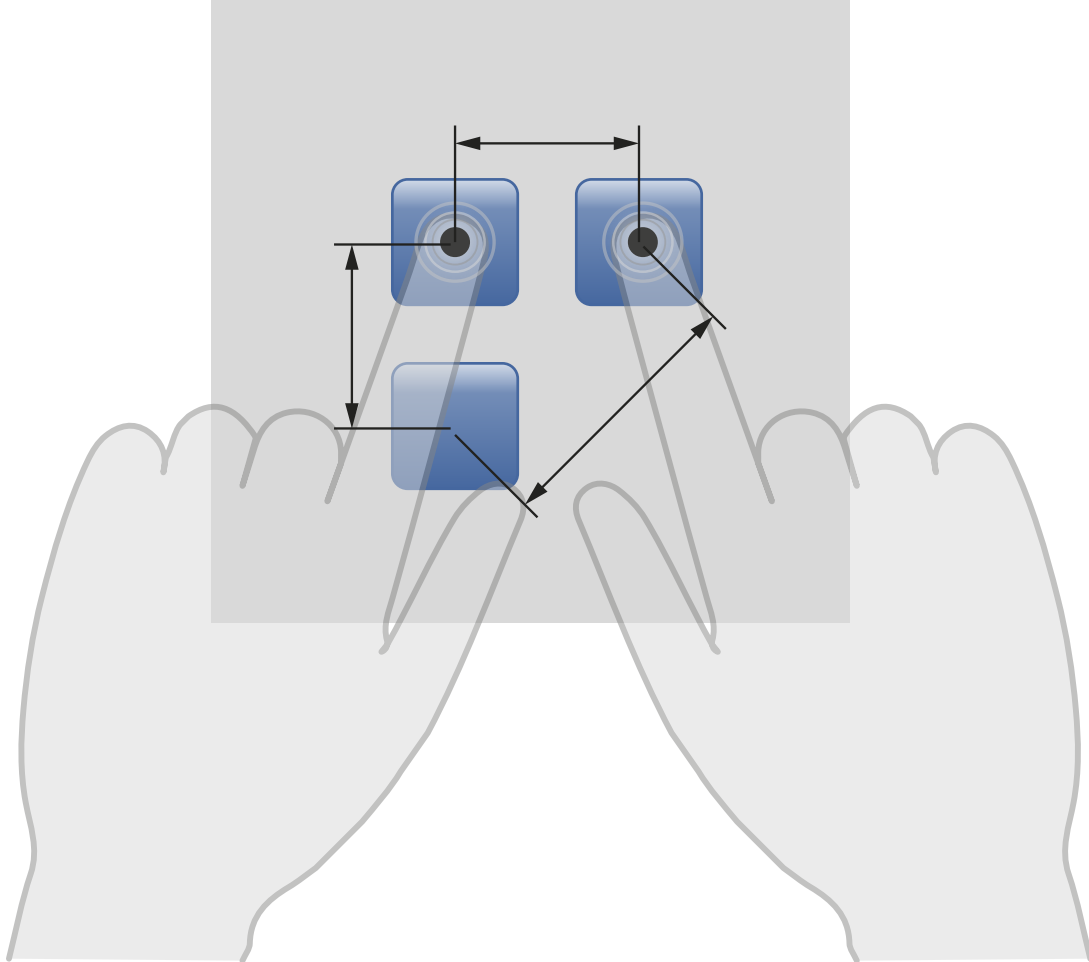

### INFORMATION



The size of the buttons and operating elements directly affect the operability of the application. Small operating elements should therefore be avoided.

## 5.7 Input

Input	Multi-touch screen (PCAP)
-------	---------------------------

## 5.8 Environmental Conditions

Storage temperature	-30 ... +70 °C	
Environmental temperature	0 ... +50 °C	
Humidity	10-95 %, non-condensing	
Installation altitude above sea level	0-2000 m without derating > 2000 m up to a maximum of 5000 m with derating of the maximum environmental temperature by 0.5 °C per 100 m	
Operating conditions	pollution degree 2	
Noise emissions	≤ 70 dB	
EMC resistance	EN 61000-6-2 (industrial area)	
EMC noise generation	EN 61000-6-4 (industrial area) EN 61000-6-3 (residential area)	
Vibration resistance	EN 60068-2-6	3.5 mm from 5-8.4 Hz 1 g from 8.4-150 Hz
Shock resistance	EN 60068-2-27	15 g (147.15 m/s <sup>2</sup> )
Protection type	EN 60529/NEMA 250	front: IP65/Type4 cover: IP20/Type1

## 5.9 Miscellaneous

Article number	01-235-0710	
Operating system	Salamander	
Default IP address	10.10.150.1	
Printed circuit board coating	no	
Approvals	CE	yes
	UL	designed according to UL
	Functional Safety	no
	UKCA	no

## 6 Interfaces

### 6.1 Rear Connectors

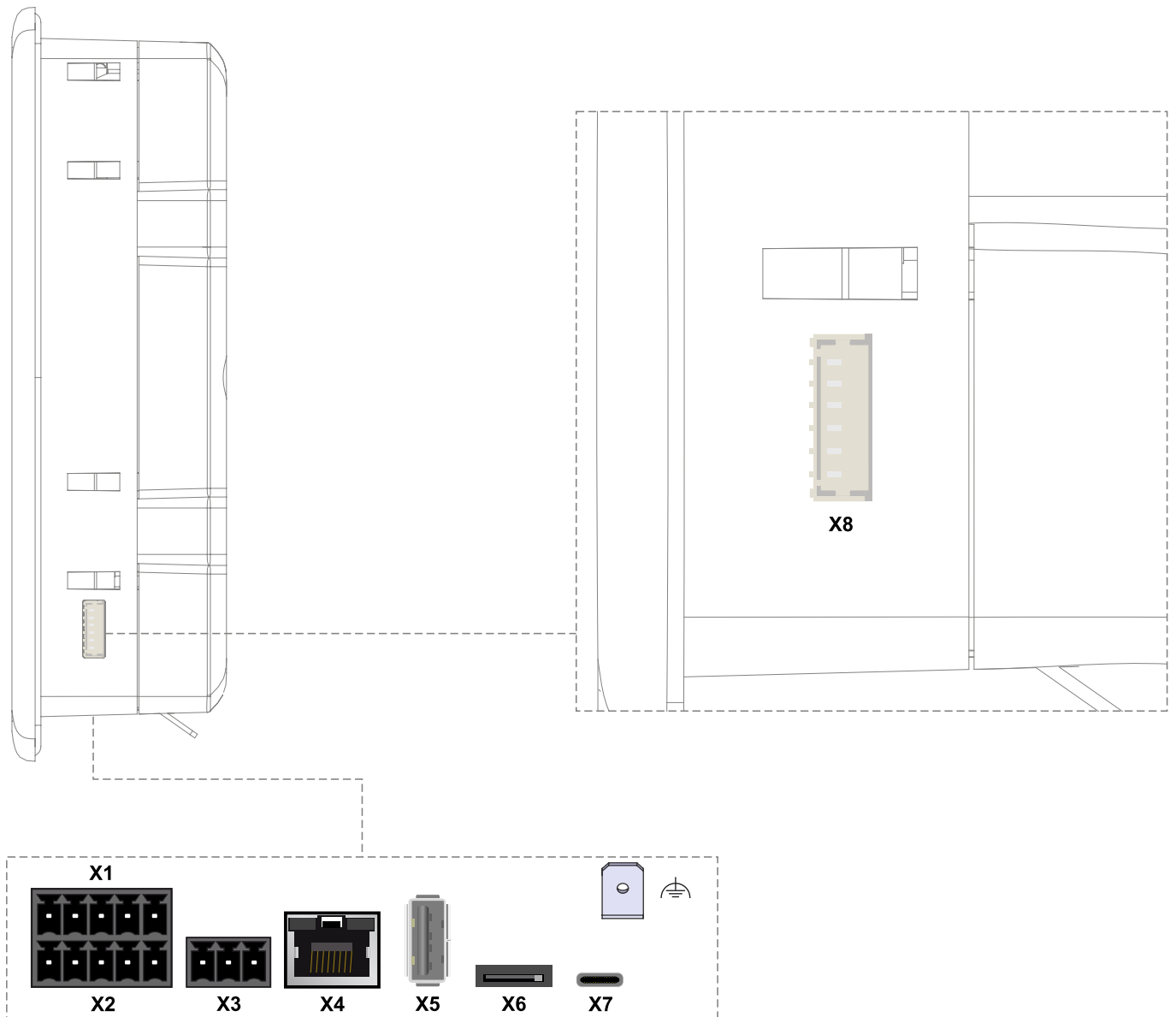

### 6.1.1 X1: CAN Bus, X2: Supply (2x 5-pin Phoenix RM 3.5)

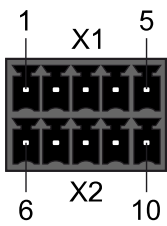

X1 Pin	Function
1	CAN A (LOW)
2	CAN B (HIGH)
3	CAN A (LOW)
4	CAN B (HIGH)
5	GND
X2 Pin	Function
6	+24 V feed-in
7	+24 V feed-in
8	GND
9	GND
10	GND

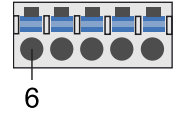
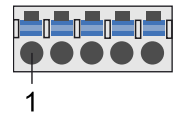

#### INFORMATION



#### CAN Bus Termination

→ The resistance can be switched on or off via hardware class.

#### CAN Bus and Supply

→ The power supply and CAN bus are internally connected via connector X8.

### 6.1.2 X3: RS485 (COM2) (3-pin Phoenix RM 3,5)

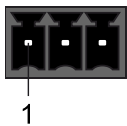

Pin	Function
1	RS485 A
2	RS485 B
3	GND

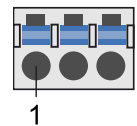

#### INFORMATION



#### Real time

→ The serial interface (X3) is not real-time capable and must be operated as a background task.

#### Termination and spreading resistance

→ The resistors can be enabled or disabled by hardware class.

### 6.1.3 X4: Ethernet (10/100 Mbit/s) (RJ45)

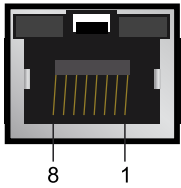

Pin	Function
1	Tx+
2	Tx-
3	Rx+
4	n.c.
5	n.c.
6	Rx-
7	n.c.
8	n.c.

n.c. = do not use

#### INFORMATION



Only for use in LAN, not for connection to telecommunication circuits.

#### INFORMATION



Problems can arise if a control is connected to an IP network, which contains modules that are not running with a SIGMATEK operating system. With such devices, Ethernet packets could be sent to the control with such a high frequency (i.e. broadcasts), that the high interrupt load could cause a real-time runtime error or runtime error. By configuring the packet filter (Firewall or Router) accordingly however, it is possible to connect a network with SIGMATEK hardware to a third party network without triggering the error mentioned above.

### 6.1.4 X5: USB 2.0, Host (Type A)

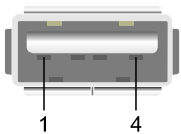

Pin	Function
1	+5 V, $I_{out,max} = 500 \text{ mA}$
2	D-
3	D+
4	GND

#### INFORMATION



##### Short circuit

- In the event of an external short circuit (e.g., defective USB stick), the voltage is switched off via a hardware component. To check whether the short circuit still exists, this component cyclically switches the voltage back on.

### 6.1.5 X6: microSD

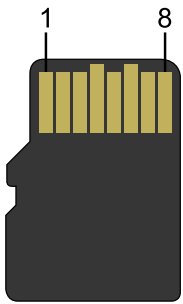

Pin	Function
1	DAT2
2	CD/DAT3
3	CMD
4	+3V3
5	CLK
6	GND
7	DAT0
8	DAT1

#### INFORMATION



It is recommended that only storage media provided by SIGMATEK be used.

The number of read and write actions have a significant influence on the lifespan of the storage media.

The microSD card is not intended as an exchangeable medium and should therefore be removed from the card holder for maintenance purposed only.

### 6.1.6 X7: USB 2.0, Host & Device (Type C)

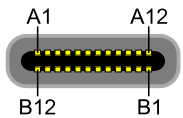

Pin	Function
A1, B1	GND
A2, B2	n.c.
A3, B3	n.c.
A4, B4	VBUS
A5, B5	CC1, CC2
A6, B6	USB2.0 D+
A7, B7	USB2.0 D-
A8, B8	n.c.
A9, B9	VBUS
A10, B10	n.c.
A11, B11	n.c.
A12, B12	GND

+5 V, I<sub>OUT MAX</sub> = 500 mA

n.c. = do not use

#### INFORMATION



It should be noted that many of the USB devices on the market do not comply with USB specifications; this can lead to device malfunctions. This may cause the device to malfunction. It is also possible that these devices will not be detected at the USB port or function correctly. It is therefore recommended that every USB stick or USB supply be tested before actual use.

### 6.1.7 X8: CAN, Supply (Molex Picoblade RM1.25)

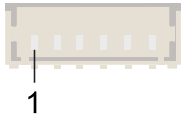

Pin	Function
1	CAN B (HIGH)
2	CAN A (LOW)
3	GND
4	+24 V feed-in
5	+24 V feed-in
6	PE

#### INFORMATION



#### CAN Bus and Supply

- The power supply and CAN bus are internally connected via connector X1 and X2.

## 6.2 Applicable Connectors

- X1, X2:** 5-pin Phoenix plug with spring terminal FMC 1.5/ 5-ST-3.5 (not included with delivery)
- X3:** 3-pin Phoenix plug with spring terminal FMC 1.5/ 5-ST-3.5 (not included with delivery)
- X4:** 8-pin RJ45 (not included with delivery)
- X5:** USB 4-pin, Type A (downstream connector) (not included with delivery)
- X7:** USB 24-pin Type C (not included with delivery)
- X8:** 6-pin Molex plug Picoblade RM1.25 (Molex 51021-06001) or equivalent (not included with delivery)

## 6.3 Status Display LEDs

One multi status LED for diagnostics is located on the front.

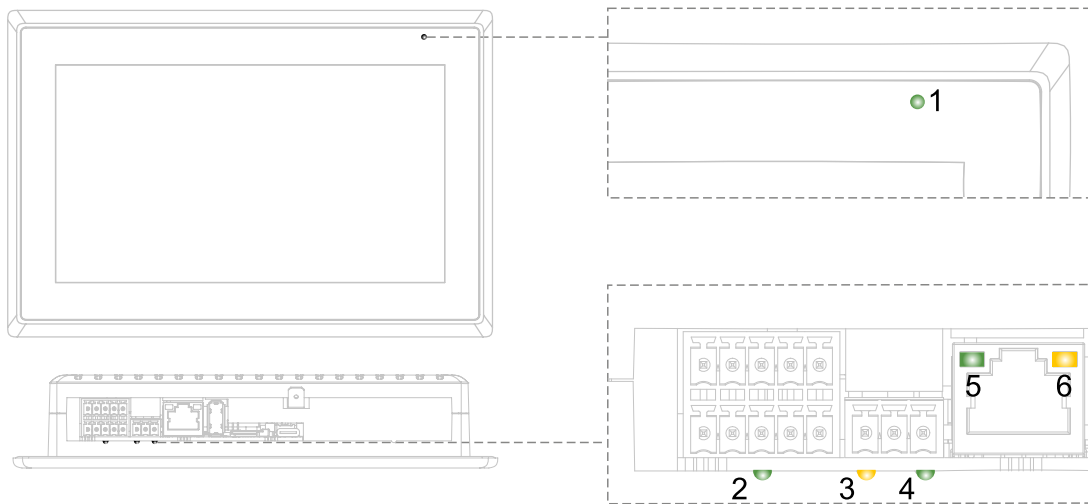

LED	Status	Color	Condition	Description
1	DC OK	green	ON	Supply voltage OK
			OFF	Supply voltage NOT OK
Software-adjustable (On, Blinks, Off)				
1	Error	red	ON	no boot media
			BLINKS	Application RESET
			OFF	Boot medium found / Application RUN
Software-adjustable (On, Blinks, Off)				
2	Abschluss CAN	green	ON	CAN termination is active.
3	Spreizung RS485	yellow	ON	RS485 spreading is active.
4	Abschluss RS485	green	ON	RS485 termination is active.
5	ETH Activity	green	ON	Link established
			BLINKS	during activity (send & receive)
6	ETH Link/ Speed	yellow	ON	100 Mbit Ethernet connection
			OFF	10 Mbit Ethernet connection
			no Ethernet connection	

## 7 Mechanical Dimensions

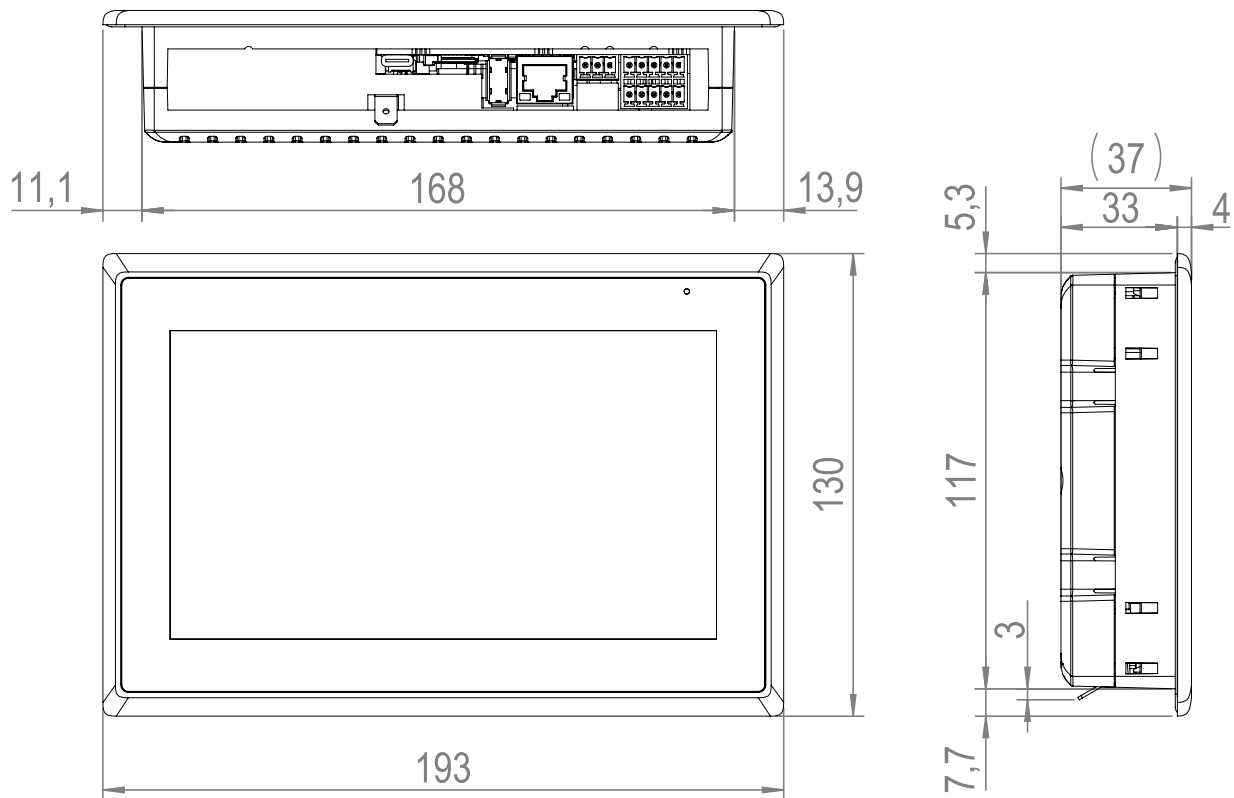

Dimensions	193 x 130 x 37 mm (W x H x D)
Material	Housing: plastic Color: black Front: glass 1.1 mm
Weight	0.40 kg

## 8 Assembly/Installation

### 8.1 Check Contents of Delivery

Ensure that the contents of the delivery are complete and intact. See chapter 1.3 Contents of Delivery.

#### INFORMATION



On receipt and before initial use, check the device for damage. If the device is damaged, contact our customer service and do not install the device in your system.

Damaged components can disrupt or damage the system.

### 8.2 Installation

To ensure the necessary air circulation for cooling, the mounting instructions must be followed!

### 8.3 Mounting Instructions

The following instructions must be followed when installing the terminal:

- For installation with the screw terminals provided, it is recommended that the installation panel have a material strength of 1.5 mm and maximum 5.0 mm. The screw-in brackets can be tightened with a torque of 0.1 Nm. For this purpose, a 3 x 0.5 flat-tip screw driver is required.
- To avoid damage to the terminal, it is important to ensure that during installation, the contact surface is clean (free of debris, uneven areas). Unevenness can lead to stress or contamination from dust and water.

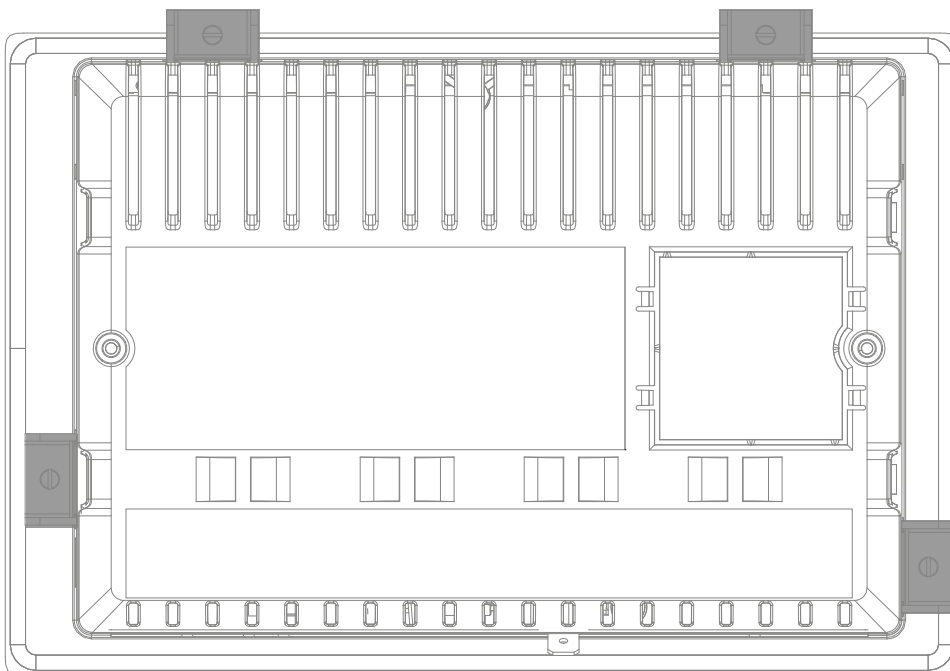

Attachement points to ensure tightness

### 8.3.1 Required Cutout for Mounting the Terminal

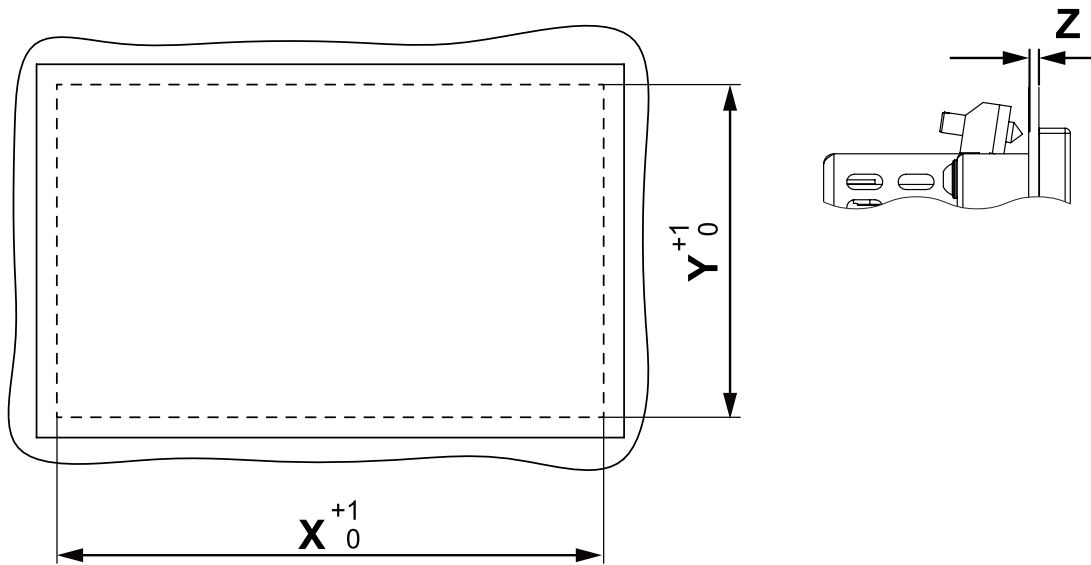

Control cabinet cutout width X	169 mm
Control cabinet cutout height Y	118 mm
Maximum thickness of control cabinet wall Z	5.0 mm

### 8.3.2 Mounting Position

Observe the mounting position of 60-120°.

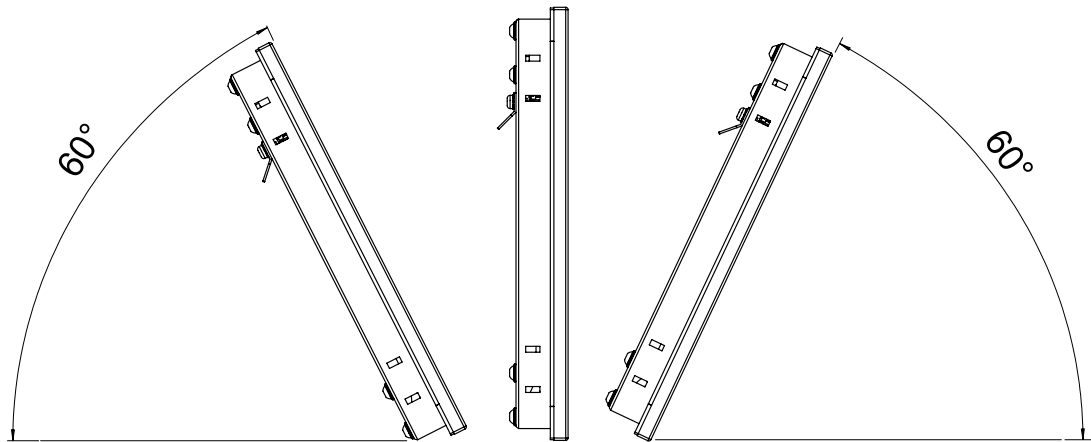

#### INFORMATION



The specified installation distances may be reduced if appropriate measures and technical precautions are taken to dissipate the corresponding waste heat.

### 8.3.3 Minimum Distance Installation

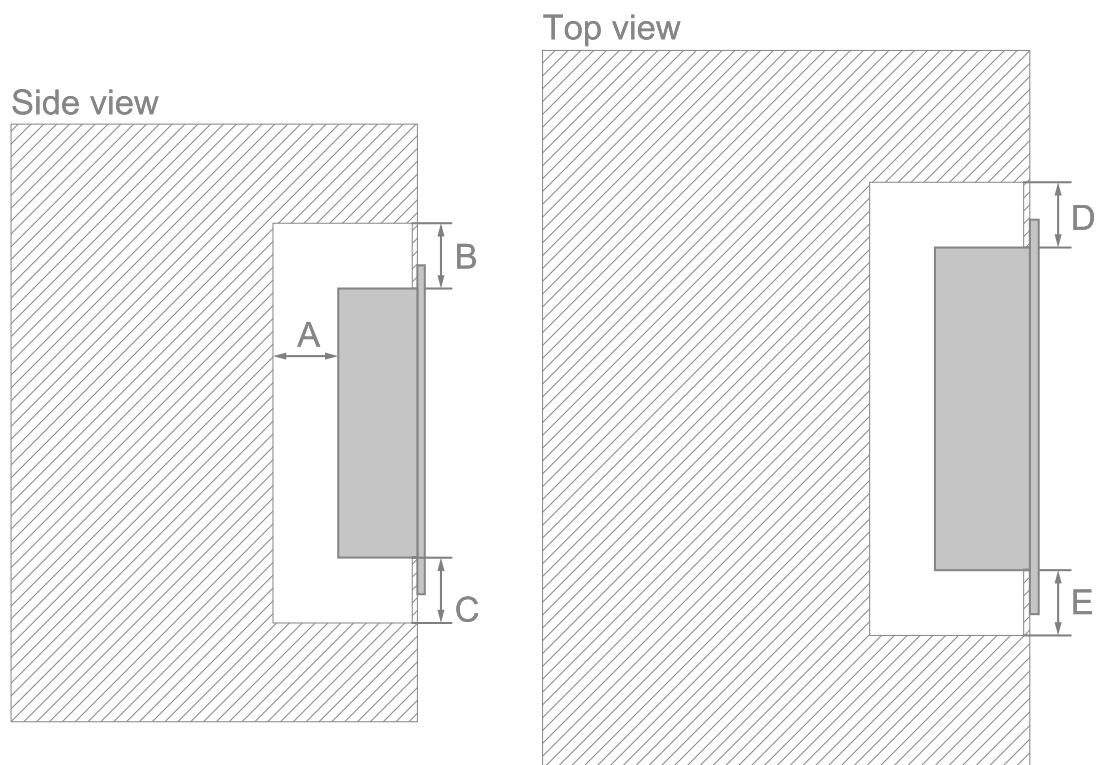

A	110 mm
B	40 mm
C	60 mm
D	40 mm
E	40 mm

With additional suitable measures for cooling, the minimum distances can be reduced.

## 9 Wiring

### 9.1 Grounding

The device must be grounded via the blade terminal provided. In addition, ensure that when installing into the control cabinet, a large grounding surface is provided. It is important to establish a low-Ohm connection to ground to ensure error-free function. The ground connection must be made with the maximum wire cross-section and largest (electrical) surface possible. The cable length of the ground connection must also be kept as short as possible.

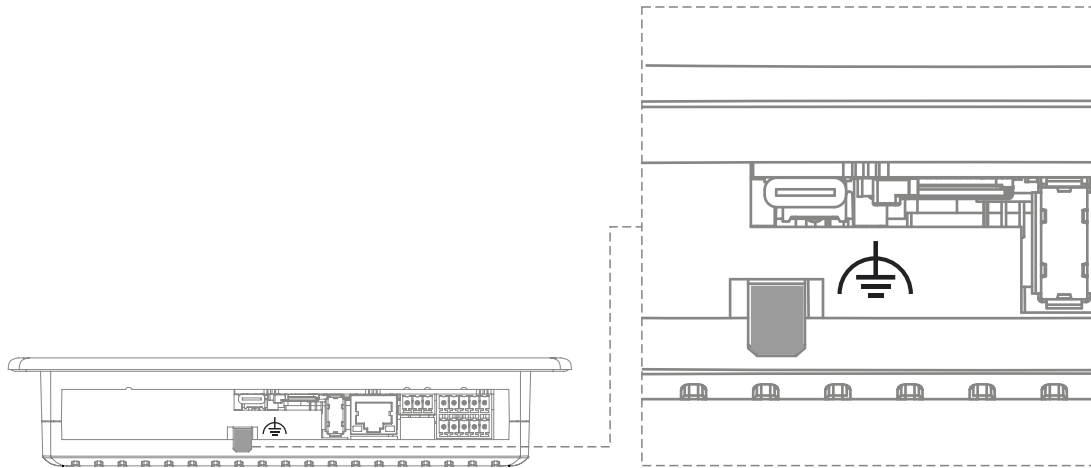

### 9.2 Shielding

For Ethernet, CAT5e (STP - Shielded Twisted Pair) cables are recommended. The cable shielding is connected to ground via the connector. Noise signals can then be prevented from reaching the electronics and affecting the function.

### 9.3 ESD Protection

#### CAUTION



The operator must ensure that no ESD interference affects the product.

L'opérateur doit s'assurer qu'aucune interférence due à des décharges électrostatiques n'affecte le produit.

### 9.4 USB Interface

The product has a USB interface. This interface can be used to connect various USB devices (keyboard, mouse, storage media, hubs, etc.). Several USB devices can be connected using a hub, which are then fully functional.

## 9.5 CAN Bus

This section explains how to correctly configure the CAN bus. The following parameters must first be set: Station number and data transfer rate.

### 9.5.1 CAN Bus Station Number

Each CAN bus station is assigned its own station number. With this station number, data can be exchanged with other stations connected to the bus. In a CAN bus system however, each station number can only be assigned once!

### 9.5.2 Number of CAN Bus Participants

The maximum number of participants on the CAN bus depends on the cable length, termination resistance, data transfer rate and the drivers used in the participants. With a termination resistance of 120  $\Omega$ , at least 100 participants are possible.

### 9.5.3 CAN Bus Data Transfer Rate

Various data transfer rates (baud rates) can be set on the CAN bus. The longer the bus line is, the lower the data transfer rate that must be selected.

These values apply to the following cable: 120  $\Omega$  Twisted Pair.

Value	Baud Rate	Maximum Length
0	615 kbit/s	60 m
1	500 kbit/s	80 m
2	250 kbit/s	160 m
3	125 kbit/s	320 m
4	100 kbit/s	400 m
5	50 kbit/s	800 m
6	20 kbit/s	1200 m
7	1 Mbit/s	30 m

#### INFORMATION



For the CAN bus protocol: 1 kbit/s = 1 kBaud

## 9.5.4 CAN Bus Termination

In a CAN bus system, both end modules must be terminated. This is necessary to avoid transmission errors caused by reflections in the line.

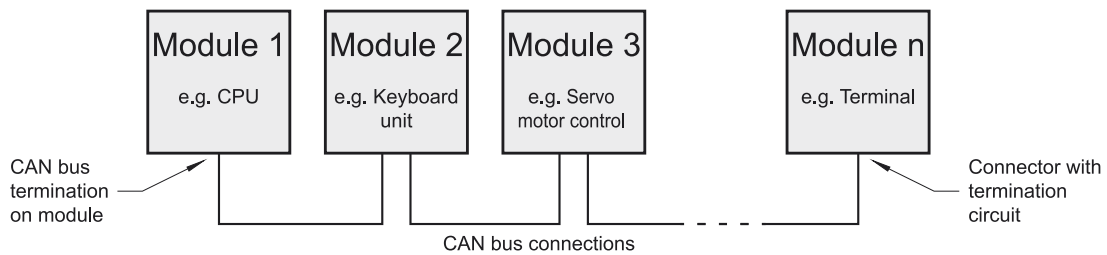

Example

### INFORMATION



The termination is made by an internal  $120\ \Omega$  resistor between CAN A (LOW) and CAN B (HIGH).

## 9.6 RS485

- Since RS485 requires a defined idle level, a pull-up and a pull-down resistor are required in addition to the terminating resistor (spreading) (can be activated via software).
- The  $120\ \Omega$  terminating resistors must be placed at the end of the bus (can be activated via software).
- Star wiring should be avoided.

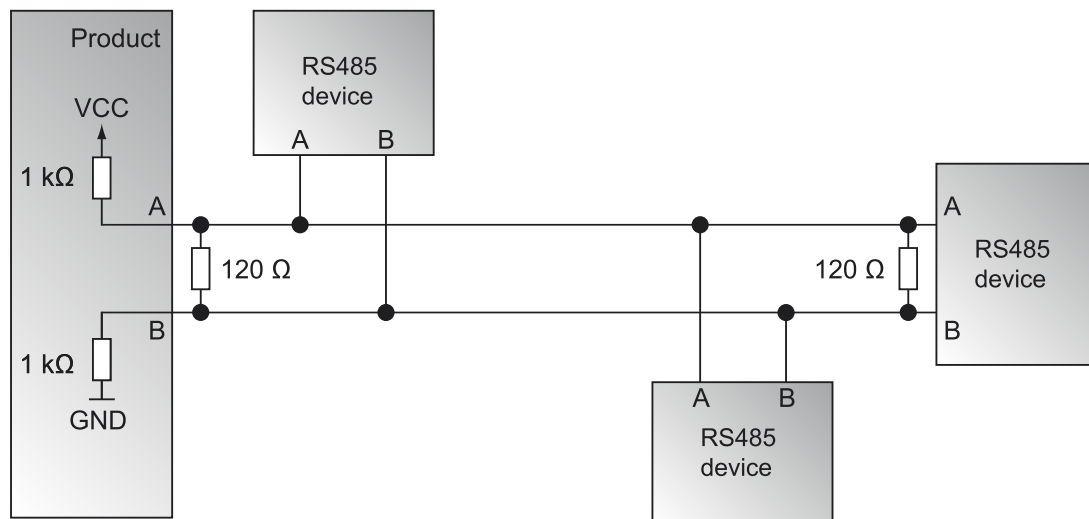

# 10 Process Diagram

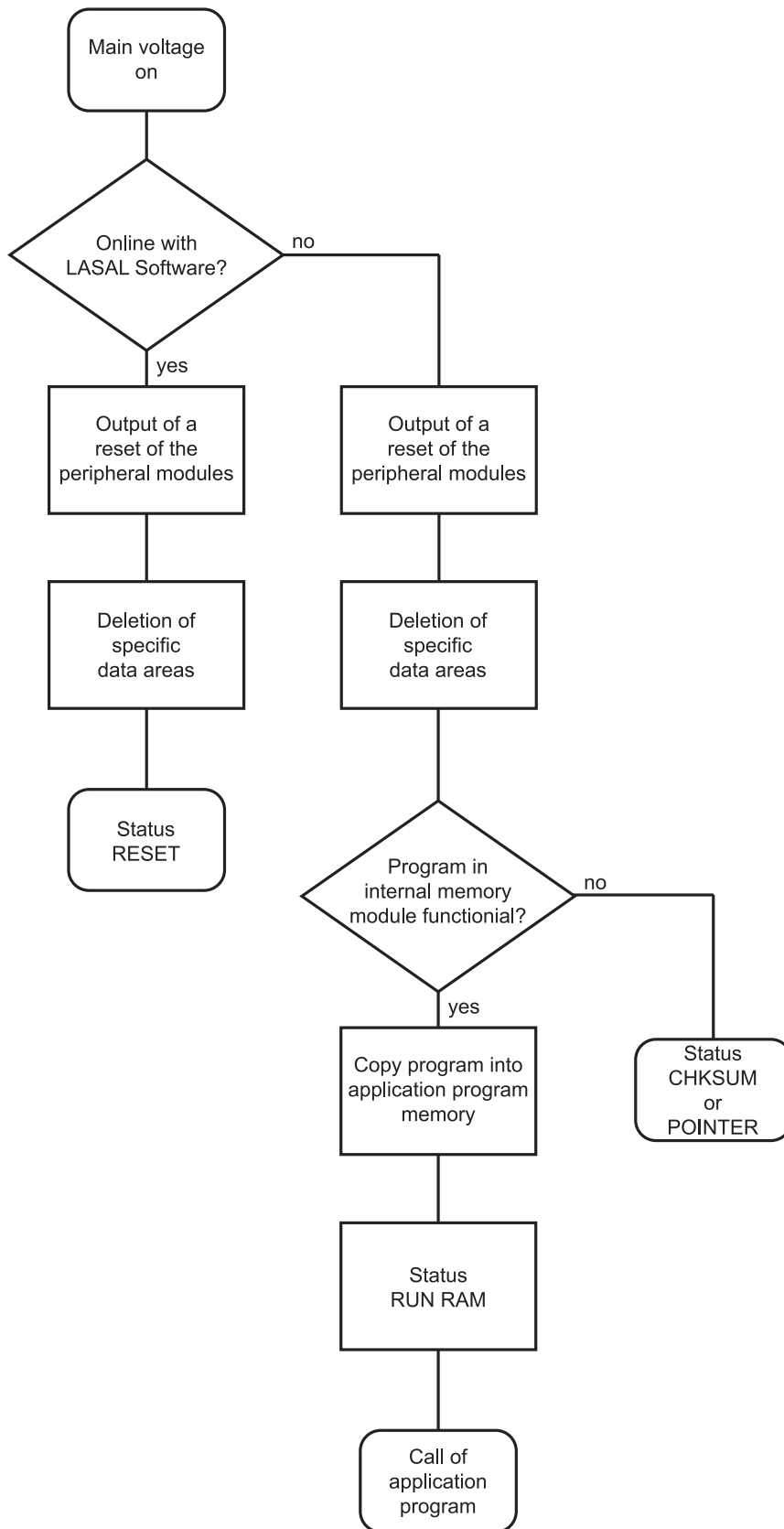

## 11 Status and Error Messages

Status and error messages are shown in the status test of the LASAL CLASS software. POINTER or CHKSUM messages can also be shown on the screen.

Number	Message	Definition	Cause/Solution
00	<b>RUN RAM</b>	The user program is currently running in RAM. The display is not affected.	Info
01	<b>RUN ROM</b>	The user program stored in the program memory module was loaded into the RAM and is currently running. The display is not affected.	Info
02	<b>RUNTIME</b>	The total time for all cyclic objects exceeds the maximum time; the time can be configured using 2 system variables: <ul style="list-style-type: none"> <li>▪ Runtime: Remaining time</li> <li>▪ SWRuntime: Preset value for runtime counter</li> </ul>	Optimize the application's cyclic task. Use higher capacity CPU. Configure preset value
03	<b>POINTER</b>	Incorrect program pointers were detected before running the user program	Possible Causes: <ul style="list-style-type: none"> <li>▪ The program memory module is missing, not programmed or defective.</li> <li>▪ The program in the user program memory (RAM) is not executable.</li> <li>▪ The buffer battery has failed.</li> <li>▪ The user program has overwritten a software error.</li> </ul> Solution: <ul style="list-style-type: none"> <li>▪ Reprogram the memory module, if the error reoccurs exchange the module.</li> <li>▪ Exchange the buffering battery</li> <li>▪ Correct programming error</li> </ul>
04	<b>CHKSUM</b>	An invalid checksum was detected before running the user program.	Cause/Solution: s. POINTER

Number	Message	Definition	Cause/Solution
05	WATCHDOG	The program was interrupted via the watchdog logic.	Possible Causes: <ul style="list-style-type: none"> <li>▪ User program interrupts blocked over a longer period of time (STI command forgotten).</li> <li>▪ Programming error in a hardware interrupt.</li> <li>▪ INB, OUTB, INW, OUTW instructions used incorrectly.</li> <li>▪ The processor is defective.</li> </ul> Solution: <ul style="list-style-type: none"> <li>▪ Correct programming error.</li> <li>▪ Exchange CPU</li> </ul>
06	GENERAL ERROR	General error An error has occurred while stopping the application via the online interface.	This error occurs only during the development of the operating system.
07	PROM DEFECT	An error has occurred while programming the memory module.	Causes: <ul style="list-style-type: none"> <li>▪ The program memory module is defective.</li> <li>▪ The user program is too large.</li> <li>▪ The program memory module is missing.</li> </ul> Solution: <ul style="list-style-type: none"> <li>▪ Exchange the program memory module</li> </ul>
08	RESET	The CPU has received the reset signal and is waiting for further instructions. The user program is not processed.	Info
09	WD DEFECT	The hardware monitoring circuit (watchdog logic) is defective. After power-up, the CPU checks the watchdog logic function. If an error occurs during this test, the CPU deliberately enters an infinite loop from which no further instructions are accepted.	Solution: <ul style="list-style-type: none"> <li>▪ Exchange CPU</li> </ul>
10	STOP	The program was stopped by the programming system.	
11	PROG BUSY	Reserved	
12	PROGRAM LENGTH	Reserved	
13	PROG END	A memory module was successfully programmed.	Info
14	PROG MEMO	The CPU is currently programming the memory module.	Info

Number	Message	Definition	Cause/Solution
15	STOP BRKPT	The CPU was stopped by a breakpoint in the program.	Info
16	CPU STOP	The CPU was stopped by the programming software.	Info
17	INT ERROR	The CPU has triggered a false interrupt and stopped the user program or has encountered an unknown instruction while running the program.	<p>Causes:</p> <ul style="list-style-type: none"> <li>■ A nonexistent operating system was used.</li> <li>■ Stack error (uneven number of PUSH and POP instructions).</li> <li>■ The user program was interrupted by a software error.</li> </ul> <p>Solution:</p> <ul style="list-style-type: none"> <li>■ Correct programming error.</li> </ul>
18	SINGLE STEP	The CPU is in single step mode and is waiting for further instructions.	Info
19	READY :	A module or project has been sent to the CPU and it is ready to run the program.	Info
20	LOAD	The program is stopped and the CPU is currently receiving a new module or project.	Info
21	INVALID MODULE	The CPU has received a module that does not belong to the project.	<p>Solution:</p> <ul style="list-style-type: none"> <li>■ Recompile and download the entire project</li> </ul>
22	MEMORY FULL	The operating system memory (heap) is too small. No memory could be reserved while calling an internal function or an interface function is called from the application.	<p>Causes:</p> <ul style="list-style-type: none"> <li>■ Memory is only allocated but not released.</li> </ul> <p>Solution:</p> <ul style="list-style-type: none"> <li>■ Clear memory</li> </ul>
23	NOT LINKED	When starting the CPU, a missing module or a module that does not belong to the project was detected.	<p>Solution:</p> <ul style="list-style-type: none"> <li>■ Recompile and download the entire project</li> </ul>
24	DIV BY 0	A division error has occurred.	<p>Possible Causes:</p> <ul style="list-style-type: none"> <li>■ Division by 0.</li> <li>■ The result of a division does not fit in the result register.</li> </ul> <p>Solution:</p> <ul style="list-style-type: none"> <li>■ Correct programming error.</li> </ul>
25	DIV BY 0	A division error has occurred.	<p>Possible Causes:</p> <ul style="list-style-type: none"> <li>■ Division by 0.</li> <li>■ The result of a division does not fit in the result register. Solution: Correct programming error.</li> </ul>

Number	Message	Definition	Cause/Solution
25	<b>DIAS ERROR</b>	While accessing a DIAS module, an error has occurred.	Hardware problem
26	<b>WAIT</b>	The CPU is busy.	Info
27	<b>OP PROG</b>	The operating system is currently being reprogrammed.	Info
28	<b>OP INSTALLED</b>	The operating system has been reinstalled.	Info
29	<b>OS TOO LONG</b>	The operating system cannot be loaded; too little memory.	Restart, report error to SIGMATEK.
30	<b>NO OPERATING SYSTEM</b>	Boot loader message, no operating system found in RAM.	Restart, report error to SIGMATEK.
31	<b>SEARCH FOR OS</b>	The boot loader is searching for the operating system in RAM.	Restart, report error to SIGMATEK.
32	<b>NO DEVICE</b>	Reserved	
33	<b>UNUSED CODE</b>	Reserved	
34	<b>MEM ERROR</b>	The operating system loaded does not match the hardware configuration.	Solution: <ul style="list-style-type: none"> <li>■ Use the correct operating system version</li> </ul>
35	<b>MAX IO</b>	Reserved	
36	<b>MODULE LOAD ERROR</b>	The LASAL Module or project cannot be loaded.	Solution: <ul style="list-style-type: none"> <li>■ Recompile and download the entire project</li> </ul>
37	<b>BOOTIMAGE FAILURE</b>	A general error has occurred while loading the operating system.	Contact SIGMATEK
38	<b>APPLMEM ERROR</b>	An error has occurred in the application memory (user heap).	Solution: <ul style="list-style-type: none"> <li>■ Correct allocated memory access error</li> </ul>
39	<b>OFFLINE</b>	This error does not occur in the control.	This error code is used in the programming system to show that there is no connection to the control.
40	<b>APPL LOAD</b>	Reserved	
41	<b>APPL SAVE</b>	Reserved	
44	<b>VARAN MANAGER ERROR</b>	An error number was entered in the VARAN manager and stopped the program.	Solution: <ul style="list-style-type: none"> <li>■ Read LogFile</li> </ul>
45	<b>VARAN ERROR</b>	A required VARAN client was disconnected or a communication error has occurred.	Solution: <ul style="list-style-type: none"> <li>■ Read LogFile error tree</li> </ul>

Number	Message	Definition	Cause/Solution
46	APPL-LOAD-ERROR	An error has occurred while loading the application.	Cause: <ul style="list-style-type: none"> <li>■ Application was deleted.</li> </ul> Solution: <ul style="list-style-type: none"> <li>■ Reload the application into the control.</li> </ul>
47	APPL-SAVE-ERROR	An error has occurred while attempting to save the application.	
50	ACCESS-EXCEPTION-ERROR	Read or write access of a restricted memory area. (I.e. writing to the NULL pointer).	Solution: <ul style="list-style-type: none"> <li>■ Correct application errors</li> </ul>
51	BOUND EXCEEDED	An exception error has occurred while accessing arrays. The memory area was overwritten by accessing an invalid element.	Solution: <ul style="list-style-type: none"> <li>■ Correct application errors</li> </ul>
52	PRIVILEGED INSTRUCTION	An unauthorized instruction for the current CPU level was given. For example, setting the segment register.	Cause: <ul style="list-style-type: none"> <li>■ The application has overwritten the application program code.</li> </ul> Solution: <ul style="list-style-type: none"> <li>■ Correct application errors</li> </ul>
53	FLOATING POINT ERROR	An error has occurred during a floating-point operation.	
60	DIAS-RISC-ERROR	Error from the Intelligent DIAS Master.	Restart, report error to SIGMATEK.
64	INTERNAL ERROR	An internal error has occurred, all applications are stopped.	Restart, report error to SIGMATEK.
65	FILE ERROR	An error has occurred during a file operation.	
66	DEBUG ASSERTION FAILED	Internal error	Restart, report error to SIGMATEK.
67	REALTIME RUNTIME	The total duration of all real-time objects exceeds the maximum time; the time cannot be configured. 2 ms for 386 CPUs 1 ms for all other CPUs	Solution: <ul style="list-style-type: none"> <li>■ Optimize the application's real-time task (RtWork).</li> <li>■ Reduce the clock time for the real-time task of all objects.</li> <li>■ Correct application errors</li> <li>■ CPU is overloaded in real-time =&gt; use a higher capacity CPU.</li> </ul>
68	BACKGROUND RUNTIME	The total time for all background objects exceeds the maximum time; the time can be configured using 2 system variables: - BTRuntime: -SWBTRuntime: pre-selected value for the runtime counter	Solution: <ul style="list-style-type: none"> <li>■ Optimize the application's background task (background)</li> <li>■ Use higher capacity CPU</li> <li>■ Set SWBTRuntime correctly</li> </ul>

Number	Message	Definition	Cause/Solution
70	C-DIAS ERROR	A connection error with a C-DIAS module has occurred.	Cause: <ul style="list-style-type: none"> <li>■ The cause of the error is documented in the log file</li> </ul> Solution: <ul style="list-style-type: none"> <li>■ This depends on the cause</li> </ul>
72	S-DIAS ERROR	A connection error with an S-DIAS module has occurred.	Possible Causes: <ul style="list-style-type: none"> <li>■ Real network does not match the project, S-DIAS client is defective</li> </ul> Solution: <ul style="list-style-type: none"> <li>■ Analyze log file</li> </ul>
75	SRAM ERROR	An error occurred while initializing, reading or writing SRAM data.	Possible Causes: <ul style="list-style-type: none"> <li>■ SRAM configured incorrectly</li> <li>■ Battery for powering the internal program memory is empty</li> </ul> Solution: <ul style="list-style-type: none"> <li>■ Analyze log file (Event00.log, Event19.log)</li> <li>■ Check configuration</li> <li>■ Exchange battery for powering the internal program memory</li> </ul>
95	USER DEFINED 0	User-definable code.	
96	USER DEFINED 1	User-definable code.	
97	USER DEFINED 2	User-definable code.	
98	USER DEFINED 3	User-definable code.	
99	USER DEFINED 4	User-definable code.	
100	C_INIT	Initialization start; the configuration is run.	
101	C_RUNRAM	The LASAL project was successfully started from RAM.	
102	C_RUNROM	The LASAL project was successfully started from ROM.	
103	C_RUNTIME		
104	C_READY	The CPU is ready for operation.	
105	C_OK	The CPU is ready for operation.	
106	C_UNKNOWN_CID	An unknown object from a stand-alone or embedded object, or an unknown base class was detected.	

Number	Message	Definition	Cause/Solution
107	C_UNKNOWN_CONSTR	The operating system class cannot be created; the operating system is probably wrong.	
108	C_UNKNOWN_OBJECT	Indicates an unknown object in an interpreter program; more the one DCC080 object.	
109	C_UNKNOWN_CHNL	The hardware module number is greater than 60.	
110	C_WRONG_CONNECT	No connection to the required channels.	
111	C_WRONG_ATTR	Wrong server attributes.	
112	C_SYNTAX_ERROR	Non-specific error. Recompile and download all project sections.	
113	C_NO_FILE_OPEN	An attempt was made to open an unknown table.	
114	C_OUTOF_NEAR	Memory allocation failed	
115	C_OUT OF_FAR	Memory allocation failed	
116	C_INCOMAPTIBLE	An object with the same name already exists but has a different class.	
117	C_COMPATIBLE	An object with the same name and class exists but must be updated.	
224	LINKING	The application is currently linking.	
225	LINKING ERROR	An error has occurred while linking.	
226	LINKING DONE	Linking is complete.	
230	OP BURN	The operating system is currently being burned into the Flash memory.	
231	OP BURN FAIL	An error has occurred while burning the operating system.	
232	OP INSTALL	The operating system is currently being installed.	
240	USV-WAIT	The power supply was disconnected; the UPS is active. The system is shutdown.	
241	REBOOT	The operating system is restarted.	

<b>Number</b>	<b>Message</b>	<b>Definition</b>	<b>Cause/Solution</b>
242	LSL SAVE		
243	LSL LOAD		
252	CONTINUE		
253	PRERUN	The application is started.	
254	PRERESET	The application is ended.	
255	CONNECTION BREAK		

## 12 Transport/Storage

This device contains sensitive electronics. During transport and storage, high mechanical stress must therefore be avoided.

For storage and transport, the same values for humidity and vibration as for operation must be maintained!

Temperature and humidity fluctuations may occur during transport. Ensure that no moisture condenses in or on the device, by allowing the device to acclimate to the room temperature while turned off.

When sent, the device should be transported in the original packaging if possible. Otherwise, packaging should be selected that sufficiently protects the product from external mechanical influences. Such as cardboard filled with air cushioning.

## 13 Storage

When not in use, store the device according to the storage conditions. See chapter 12 Transport/Storage.

### INFORMATION



During storage, ensure that all protective covers (if available) are placed correctly, so that no contamination, foreign bodies or fluids enter the device.

The existing battery in the device must be replaced after approx. 10 year/s. If the device is to be stored longer, the battery must be removed to prevent leakage.

## 14 Maintenance

During maintenance as well as servicing, observe the safety instructions from chapter 2 Basic Safety Directives.

### 14.1 Cleaning and Disinfecting the Touch Screen

#### CAUTION



Before cleaning and disinfecting the touch screen, it must first be deactivated; either by turning off the terminal or by disabling the touch screen via the application to avoid unintentionally activating functions or commands!

Avant de nettoyer et de désinfecter l'écran tactile, il faut d'abord le désactiver; soit en éteignant le terminal, soit en désactivant l'écran tactile via l'application pour éviter d'activer involontairement des fonctions ou des commandes!

The touch screen can only be cleaned with a soft, damp cloth. To dampen the cloth, a mild cleaning solution such as antistatic foam cleaner is recommended. To avoid fluids/cleaning solutions from getting into the housing, the device must not be sprayed directly. To clean, no erosive cleaning solutions, chemicals, abrasive cleansers or hard objects that can scratch or damage the touch screen may be used. The use of steam jets or compressed air is prohibited.

For disinfection, surface disinfectants on alcohol basis, which do not contain re-fattening agents, can be used. The disinfectant used must not leave any residues on the touch screen to ensure proper functioning of the touch screen.

#### WARNING



If the device is contaminated with toxic or erosive chemicals, it must be carefully cleaned as quickly as possible to prevent personal injury and machine damage!

Si l'appareil est contaminé par des produits chimiques toxiques ou érosifs, il doit être soigneusement nettoyé le plus rapidement possible afin d'éviter des dommages corporels et matériels!

#### INFORMATION



To ensure the optimal function of the device, the touch screen should be cleaned at regular intervals!

### 14.2 Service

This product was constructed for low-maintenance operation.

#### 14.2.1 Calibrating the Touch Screen

The touch screen is calibrated at the factory. You should therefore only recalibrate the touch screen when press-point changes are noticed.

This can be achieved via the following command (depending on the operating system) or the application, if the application engineer has provided the option.

```
calib
```

## 14.3 Repair

In the event of a defect/repair, send the device with a detailed error description to the address listed at the beginning of this document.

For transport conditions, see chapter 12 Transport/Storage.

### CAUTION



#### **Danger of injury from damaged components!**

- Damage to the device, especially the touch screen, poses a cut hazard. In such a case, use safety gloves.

#### **Risque de blessure par des composants endommagés !**

- Les dommages à l'appareil, en particulier à l'écran tactile, présentent un risque de coupure. Dans ce cas, utilisez des gants de sécurité.

## 15 Buffer Battery

A Lithium battery is installed at the manufacturer.

The battery has enough capacity to preserve data in the absence of a supply voltage for up to circa 10 year/s.

	COMPANY	DATA
Lithium battery	RENATA	3.0 V/225 mAh

### INFORMATION



Battery order number: 01-690-055

Use type CR2032 batteries from RENATA only.

Disconnect the device from the supply before changing the battery.

### WARNING



#### Danger of fire and explosion!

- Battery may explode if mistreated. Do not recharge, disassemble or dispose of in fire.
- Replace battery with cat. no. CR2032 manufactured by RENATA only. Use of another battery may present a risk of fire or explosion. See instruction manual for safety instructions.

#### Danger d'incendie et d'explosion !

- La batterie peut exploser si elle n'est pas manipulée correctement.
- Ne pas la recharger, la démonter ou la jeter au feu. Ne remplacez la pile que par la référence CR2032, fabriquée par RENATA. L'utilisation d'une autre pile présente un risque d'incendie ou d'explosion. Vous trouverez les consignes de sécurité dans le mode d'emploi.

### 15.1 Data Retention Battery Change

The exchangeable buffer battery ensures that the following data is preserved in the absence of a supply voltage:

- Time

If the battery is empty, the following settings are reset or data is deleted:

- Time (reset to default value)

## 16 Display „Burn-In“ Effect

The “Burn-In” effect describes a pattern burned into the display after displaying the same contents over a longer period of time (e.g. a single screen).

This effect is also described mostly as “image sticking”, “memory effect/sticking” or “ghost image”.

Here, a distinction is made between a temporary and permanent effect, while the temporary effect is eliminated by switching off the screen for a longer period of time or by displaying dynamic content, serious cases of burn-in can lead to permanent damage to the display.

This effect can have the following causes:

- Operation without a screen saver
- The same contents displayed over a longer time period (e.g. a single screen)
- Operation at high environmental temperatures
- Operation above specifications

The effect can be avoided/reduced by the following actions:

- Using a screen saver
- Deactivating the display when not in use (e.g. screen display black)
- Continuously changing screen content (e.g. video)

### INFORMATION



Deactivating the display backlighting only does not prevent Burn-In!

### 16.1 Screen Saver

The device has an integrated screen saver, which is activated by default and turns off the screen after 60 minutes of inactivity. The screen can be reactivated with an input via the touch screen or a USB operating device. The wait time for the screen saver can be adjusted in the application via the HW class. This change is only active as long as the device is running the application, in Reset mode, the 60-minute default setting is restored.

## 17 Disposal



### INFORMATION

Should you need to dispose of the device, the national regulations for disposal must be followed.

The device appliance must not be disposed of as household waste.



## 18 Accessories

### 18.1 Touch Pen



Description	Order Number
Touch pen with holder V3	01-690-059-3

### 18.2 Battery



Description	Order Number
Lithium battery RENATA	01-690-055

### 18.3 microSD Card



Description	Order Number
16 Gbyte	12-630-803

The microSD card is delivered empty and unformatted. For actual memory usage and formatting format, see performance data.

## 19 Application Information

### 19.1 Storage Media

The operating system and customer application are stored on the internal storage device.

To ensure longevity of the memory, writing cyclic data to the internal storage medium should be avoided (lifespan drastically reduced). For cyclic writing, an external storage medium (e.g. microSD card or USB stick, depending on the respective device) from SIGMATEK must be used.

Errors resulting from the use of storage media from other manufacturers are excluded from support.

#### 19.1.1 Create Boot Media (Make Bootdisk)

To create a boot medium with a SIGMATEK operating system, the PlcDiag function “Make Bootdisk” must be used. For the corresponding formatting of the storage medium, the storage medium identifier must be entered in addition to the operating system image.

HW version	Storage media identification	Storage media designation
≥ 1.x	100 (microSD)	8-Gbyte microSD (16-Gbyte 2:1 formatted ~60k P/E cycles)

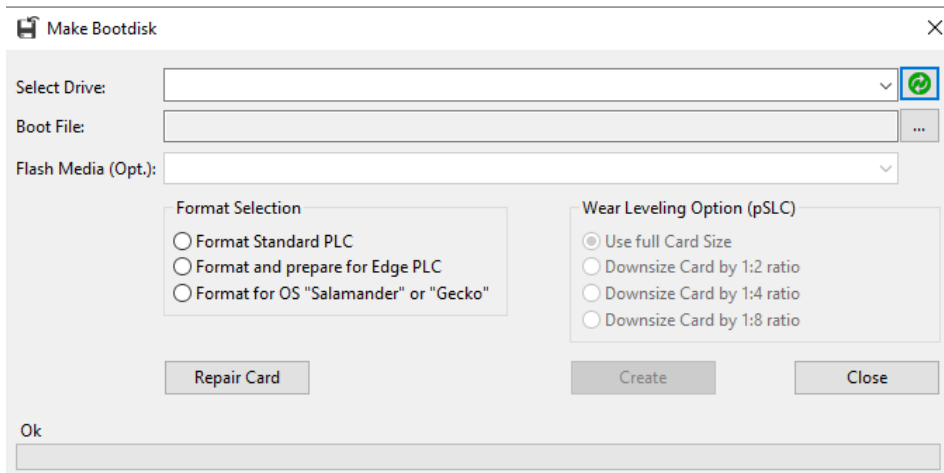

Customer-specific data can then be copied to the storage medium.

### 19.1.2 Lifetime Calculation (Flash Media Lifetime Calculation)

The life span of the internally installed storage medium can be calculated using the Flash Media Lifetime Calculation Tool. This is a theoretical guideline value. The storage medium ID must be entered to ensure the correct selection. The current status of the storage medium can be read out via the hardware class “PLC\_Info” using the “SDCardHealth” server.

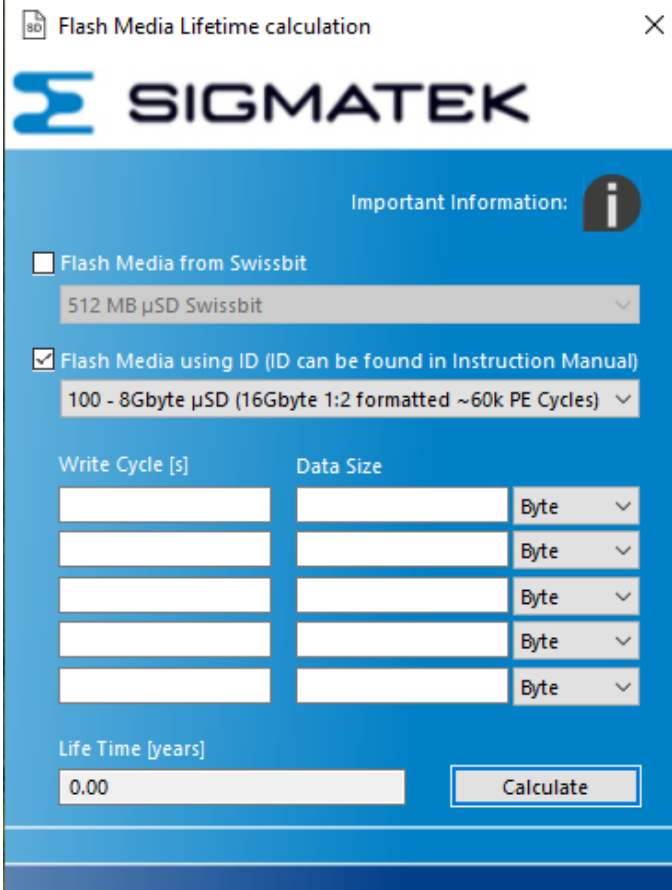

Write Cycle [s]	Data Size	Unit
<input type="text"/>	<input type="text"/>	Byte
<input type="text"/>	<input type="text"/>	Byte
<input type="text"/>	<input type="text"/>	Byte
<input type="text"/>	<input type="text"/>	Byte
<input type="text"/>	<input type="text"/>	Byte

#### INFORMATION



These extended functions of Make Bootdisk and Flash Media Lifetime Calculation are available from LASAL CLASS 2 version 02.02.244.

## Changes Chart

Change date	Affected page(s)	Chapter	Note
11.11.2025	24	8.3 Mounting Instructions	Attachment points added
20.01.2026	21	6.2 Applicable Connectors	Phoenix mating connector corrected
20.03.2026	17	6.1 Rear Connectors	X8 added, Information serial interface, USB
	21	6.2 Applicable Connectors	Connector set added