

# RO 041

## S-DIAS Relay Output Module

### Instruction Manual

**Publisher: SIGMATEK GmbH & Co KG**  
**A-5112 Lamprechtshausen**  
**Tel.: +43/6274/4321**  
**Fax: +43/6274/4321-18**  
**Email: office@sigmatek.at**  
**WWW.SIGMATEK-AUTOMATION.COM**

Copyright © 2014  
SIGMATEK GmbH & Co KG

## **Translation of the Original Instructions**

All rights reserved. No part of this work may be reproduced, edited using an electronic system, duplicated or distributed in any form (print, photocopy, microfilm or in any other process) without the express permission.

We reserve the right to make changes in the content without notice. The SIGMATEK GmbH & Co KG is not responsible for technical or printing errors in the handbook and assumes no responsibility for damages that occur through use of this handbook.

## S-DIAS Relay Output Module

**RO 041**

### with 4 relay outputs

The S-DIAS RO 041 relay output module has four relay outputs, each with normally open contacts for 230 V/6 A AC or 24 V/6 A DC.

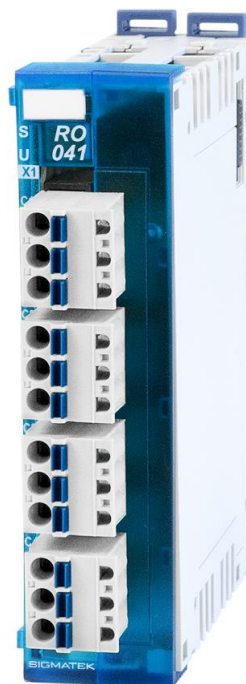

# Contents

<b>1</b>	<b>Introduction .....</b>	<b>5</b>
1.1	Target Group/Purpose of this Operating Manual .....	5
1.2	Important Reference Documentation .....	5
1.3	Contents of Delivery .....	5
<b>2</b>	<b>Basic Safety Directives .....</b>	<b>6</b>
2.1	Symbols Used .....	6
2.2	Disclaimer .....	8
2.3	General Safety Directives .....	9
2.4	Software/Training .....	10
<b>3</b>	<b>Standards and Directives .....</b>	<b>11</b>
3.1	Directives .....	11
3.1.1	EU Conformity Declaration .....	11
<b>4</b>	<b>Type Plate .....</b>	<b>12</b>
<b>5</b>	<b>Technical Data .....</b>	<b>13</b>
5.1	Relay Output Specifications .....	13
5.2	Relay Data V23061-A1007-A302 .....	14
5.3	Output Circuit .....	15
5.4	Electrical Requirements .....	16
5.5	Miscellaneous .....	18
5.6	Environmental Conditions .....	18

---

<b>6</b>	<b>Mechanical Dimensions</b> .....	<b>19</b>
<b>7</b>	<b>Connector Layout</b> .....	<b>20</b>
7.1	Status LEDs.....	20
7.2	Applicable Connectors.....	21
7.3	Label Field .....	22
<b>8</b>	<b>Wiring</b> .....	<b>23</b>
8.1	Wiring Example .....	23
8.2	Note .....	24
<b>9</b>	<b>Assembly/Installation</b> .....	<b>25</b>
9.1	Check Contents of Delivery .....	25
9.2	Mounting.....	26
<b>10</b>	<b>Transport/Storage</b> .....	<b>28</b>
<b>11</b>	<b>Storage</b> .....	<b>28</b>
<b>12</b>	<b>Maintenance</b> .....	<b>29</b>
12.1	Service .....	29
12.2	Repair.....	29
<b>13</b>	<b>Disposal</b> .....	<b>29</b>
<b>14</b>	<b>Addressing</b> .....	<b>30</b>
<b>15</b>	<b>Supported Cycle Times</b> .....	<b>31</b>

---

15.1	Cycle Times below 1 ms (in $\mu\text{s}$ ).....	31
15.2	Cycle Times equal to or higher than 1 ms (in ms) .....	31
<b>16</b>	<b>Hardware Class RO041.....</b>	<b>32</b>
16.1	Interfaces .....	33
16.1.1	Clients.....	33
16.1.2	Servers .....	33
16.1.3	Communication Interfaces .....	33
16.2	Example .....	34

# 1 Introduction

## 1.1 Target Group/Purpose of this Operating Manual

This operating manual contains all information required for the operation of the product.

This operating manual is intended for:

- Project planners
- Technicians
- Commissioning engineers
- Machine operators
- Maintenance/test technicians

General knowledge of automation technology is required.

Further help and training information, as well as the appropriate accessories can be found on our website [www.sigmatek-automation.com](http://www.sigmatek-automation.com).

Our support team is happily available to answer your questions.  
Please see our website for our hotline number and business hours.

## 1.2 Important Reference Documentation

This and additional documents can be downloaded from our website or obtained through support.

## 1.3 Contents of Delivery

1x RO 041

## 2 Basic Safety Directives

### 2.1 Symbols Used

The following symbols are used in the operator documentation for warning and danger messages, as well as informational notes:

#### DANGER



**Danger** indicates that death or serious injury **will occur**, if the specified measures are not taken.

⇒ To avoid death or serious injuries, observe all guidelines.

**Danger** indique une situation dangereuse qui, faute de prendre les mesures adéquates, **entraînera** des blessures graves, voire mortelles.

⇒ Respectez toutes les consignes pour éviter des blessures graves, voire mortelles.

#### WARNING



**Warning** indicates that death or serious injury **can** occur, if the specified measures are not taken.

⇒ To avoid death or serious injuries, observe all guidelines.

**Avertissement** d'une situation dangereuse qui, faute de prendre les mesures adéquates, **entraînera** des blessures graves, voire mortelles.

⇒ Respectez toutes les consignes pour éviter des blessures graves, voire mortelles.

#### CAUTION



**Caution** indicates that moderate to slight injury **can** occur, if the specified measures are not taken.

⇒ To avoid moderate to slight injuries, observe all guidelines.

**Attention** indique une situation dangereuse qui, faute de prendre les mesures adéquates, **peut** entraîner des blessures assez graves ou légères.

⇒ Respectez toutes les consignes pour éviter des blessures graves, voire mortelles.

**INFORMATION****Information**

- ⇒ Provides important information on the product, handling or relevant sections of the documentation, which require attention.
-

## 2.2 Disclaimer

### INFORMATION



The contents of this operating manual were prepared with the greatest care. However, deviations cannot be ruled out. This operating manual is regularly checked and required corrections are included in the subsequent versions. The machine manufacturer is responsible for the proper assembly, as well as device configuration. The machine operator is responsible for safe handling, as well as proper operation.

The current operating manual can be found on our website. If necessary, contact our support.

Subject to technical changes, which improve the performance of the devices. The following operating manual is purely a product description. It does not guarantee properties under the warranty.

Please thoroughly read the corresponding documents and this operating manual before handling a product.

**SIGMATEK GmbH & Co KG is not liable for damages caused through, non-compliance with these instructions or applicable regulations.**

## 2.3 General Safety Directives

The Safety Directives in the other sections of this operating manual must be observed. These instructions are visually emphasized by symbols.

### INFORMATION



According to EU Directives, the operating manual is a component of a product.

This operating manual must therefore be accessible in the vicinity of the machine since it contains important instructions.

This operating manual should be included in the sale, rental or transfer of the product, or its online availability indicated.

Regarding the requirements for Safety and health connected to the use of machines, the manufacturer must perform a risk assessment in accordance with machine directives 2006/42/EG before introducing a machine to the market.

Operate the unit with devices and accessories approved by SIGMATEK only.

**CAUTION**

Handle the device with care and do not drop or let fall.

Prevent foreign bodies and fluids from entering the device.

The device must not be opened!

Manipulez l'appareil avec précaution et ne le laissez pas tomber.

Empêchez les corps étrangers et les liquides de pénétrer dans l'appareil.

L'appareil ne doit pas être ouvert!

If the device does not function as intended or has damage that could pose a danger, it must be replaced!

En cas de fonctionnement non conforme ou de dommages pouvant entraîner des risques, l'appareil doit être remplacé!

The module complies with EN 61131-2.

In combination with a facility, the system integrator must comply with EN 60204-1 standards.

For your own safety and that of others, compliance with the environmental conditions is essential.

Le module est conforme à la norme EN 61131-2.

En combinaison avec une équipement, l'intégrateur de système doit respecter la norme EN 60204-1.

Pour votre propre sécurité et celle des autres, le respect des conditions environnementales est essentiel.

## 2.4 Software/Training

The application is created with the software LASAL CLASS 2 and LASAL SCREEN Editor.

Training for the LASAL development environment, with which the product can be configured, is provided. Information on our training schedule can be found on our website.

## 3 Standards and Directives

### 3.1 Directives

The product was constructed in compliance with the following European Union directives and tested for conformity.

#### 3.1.1 EU Conformity Declaration



---

#### EU Declaration of Conformity

The product RO 041 conforms to the following European directives:

- **2014/35/EU** Low-voltage Directive
- **2014/30/EU** Electromagnetic Compatibility (EMC Directive)
- **2011/65/EU** “Restricted use of certain hazardous substances in electrical and electronic equipment” (RoHS Directive)

The EU Conformity Declarations are provided on the SIGMATEK website. See Products/Downloads or use the search function and the keyword “EU Declaration of Conformity”.

---

## 4 Type Plate

	HW: X.XX
	SW: XX.XX.XXX
	Safety Version: SXX.XX.XX
Serial No.	SIGMATEK GMBH & CO KG Sigmatekstrasse 1 A-5112 LAMPRECHTSHAUSEN
Article Number	Product Name Short Name

### Exemplary nameplate (symbol image)

	HW: 1.00
	SW: 01.00.000
	Safety Version: S01.00.00
12345678	SIGMATEK GMBH & CO KG Sigmatekstrasse 1 A-5112 LAMPRECHTSHAUSEN
12-246-133-3	Handbediengerät Wireless HGW 1033-3

HW: Hardware version

SW: Software version

## 5 Technical Data

### 5.1 Relay Output Specifications

Number	4	
Contact	normally open	
Relay type	V23061-A1007-A302	
Nominal voltage	24 V DC	230 V AC
Switching voltage	maximum 30 V	maximum 250 V AC
Maximum continuous current /channel	maximum 6 A DC	maximum 6 A AC
Simultaneity of all outputs	100 %	
Maximum continuous current per connector plug contact allowed	10 A DC	10 A AC
Turn-on delay	≤ 10 ms	
Turn-off delay	≤ 10 ms	

## 5.2 Relay Data V23061-A1007-A302

### Miniature Power PCB Relay MSR V23061

- 1 pole 8/10A, 1form C (C0) or 1 form A (NO) contact
- High inrush currents with AgSnO<sub>2</sub> contacts (TV4 0 65A)
- 4kV/8mm coil-contact
- Reinforced insulation (protection class II)
- Ambient temperature up to 85°C at 8A
- Plastic materials according to IEC 60335-1 (domestic appliances)



**Typical applications**

HVAC, interface technology, PLC's, power supplies, TV-/monitor control, domestic appliances, Hi-Fi products, timers.



**Approvals**

VDE Cert. No. 40017849, UL E214025  
 Technical data of approved types on request.

**Contact Data**

Contact arrangement	1 form C (C0) or 1 form A (NO)
Rated voltage	250VAC
Max. switching voltage	400VAC
Rated current	
versions A, B	8A
versions C, D	10A
Limiting making current, max 4s, df 10%	15A
version A302, max 20ms	65A
Breaking capacity max.	2000VA
Contact material	AgSnO <sub>2</sub> , AgNi90/10
Frequency of operation, with/without load	6/1200min-1
Operate/release time max.	10/5ms
Bounce time max., form A/form B	3/10ms

**Contact ratings**

Type	Contact	Load	Cycles
<b>IEC 61810</b>			
V23061-A1***-A302	A (NO)	8A, 250VAC, cosφ=1, 85°C	100x10 <sup>3</sup>
V23061-C2***-A802	A (NO)	10A, 250VAC, cosφ=1, 85°C	100x10 <sup>3</sup>
V23061-C2***-A802	A (NO)	5A, 250VAC, cosφ=1, 105°C	100x10 <sup>3</sup>
<b>UL 508</b>			
V23061-A1***-A302	A (NO)	TV4, Tungsten, 120VAC, 40°C	25x10 <sup>3</sup>
V23061-A1***-A302	A (NO)	Pilot duty, A300, 40°C	6x10 <sup>3</sup>
V23061-C2***-A802	A (NO)	10A, 240VAC, general purpose, 40°C	30x10 <sup>3</sup>
<b>EN60730-1</b>			
V23061-A1***-A302	A (NO)	2(2)A, 250VAC, 85°C	100x10 <sup>3</sup>
V23061-C2***-A802	A (NO)	4(4)A, 250VAC, 85°C	100x10 <sup>3</sup>

Mechanical endurance, DC coil 10x10<sup>6</sup> operations

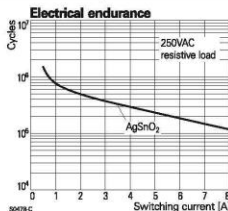
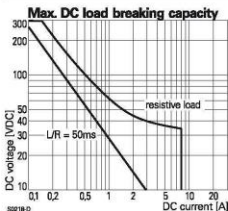

**Coil Data**

Coil voltage range	3 to 60VDC
Operative range, IEC 61810	2
Coil insulation system according UL	classA or classF

**Coil versions, DC coil**

Coil code	Rated voltage VDC	Operate voltage VDC	Release voltage VDC	Coil resistance Ω±10% <sup>1)</sup>	Rated coil power mW
001	3	2.1	0.3	40	225
002	5	3.4	0.5	118	212
003	6	4.1	0.6	165	218
004	9	6.1	0.9	364	223
005	12	8.2	1.2	652	221
007	24	16.3	2.4	2270	254
009	48	32.6	4.8	8790	262
010	60	40.8	6.0	15265 <sup>1)</sup>	236

<sup>1)</sup> Coil resistance ±15%.  
 All figures are given for coil without pre-energization, at ambient temperature +23°C.  
 Other coil voltages on request.

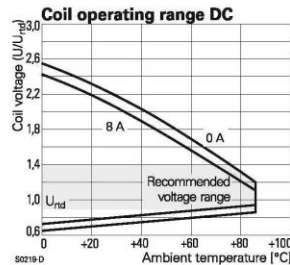

**Insulation Data**

Initial dielectric strength	
between open contacts	1000V <sub>1min</sub>
between contact and coil	4000V <sub>1min</sub>
Clearence/creepage	
between contact and coil	≥8/8mm
Material group of insulation parts	IIla

### 5.3 Output Circuit

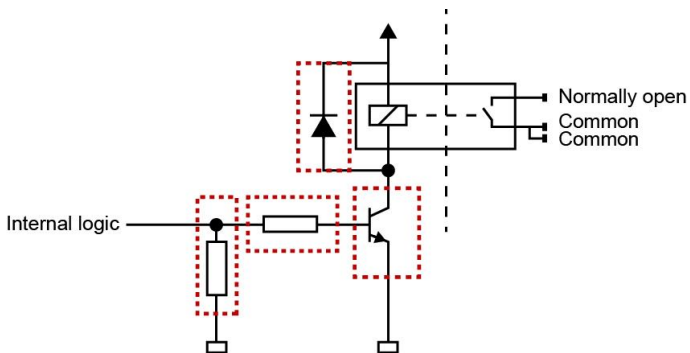

## 5.4 Electrical Requirements

Voltage supply from S-DIAS bus	+5 V	
Current consumption on the S-DIAS bus (+5 V supply)	typically 38 mA	maximum 48 mA
Voltage supply from S-DIAS bus	+24 V	
Current consumption on the S-DIAS bus (+24 V supply) (all relays active)	typically 37 mA at +18 V typically 50 mA at +24 V typically 62 mA at +30 V	maximum 44 mA at +18 V maximum 58 mA at +24 V maximum 73 mA at +30 V

### INFORMATION



When using the relay output mode, the following minimum supply voltages are required on the supply module depending on the ambient temperature:

18 V: ambient temperature -25 ... +30 °C

18.7 V: ambient temperature +40

19.4 V: ambient temperature +50

20.0 V: ambient temperature +60

### INFORMATION



If this S-DIAS module is connected to an S-DIAS supply module with several S-DIAS modules, the total current of the modules used must be determined and checked.

The total current of the +24 V supply cannot exceed 1.6 A!

The total current of the +5 V supply cannot exceed 1.6 A!

The specification for the current can be found in the module-specific documentation under "Electrical Requirements".

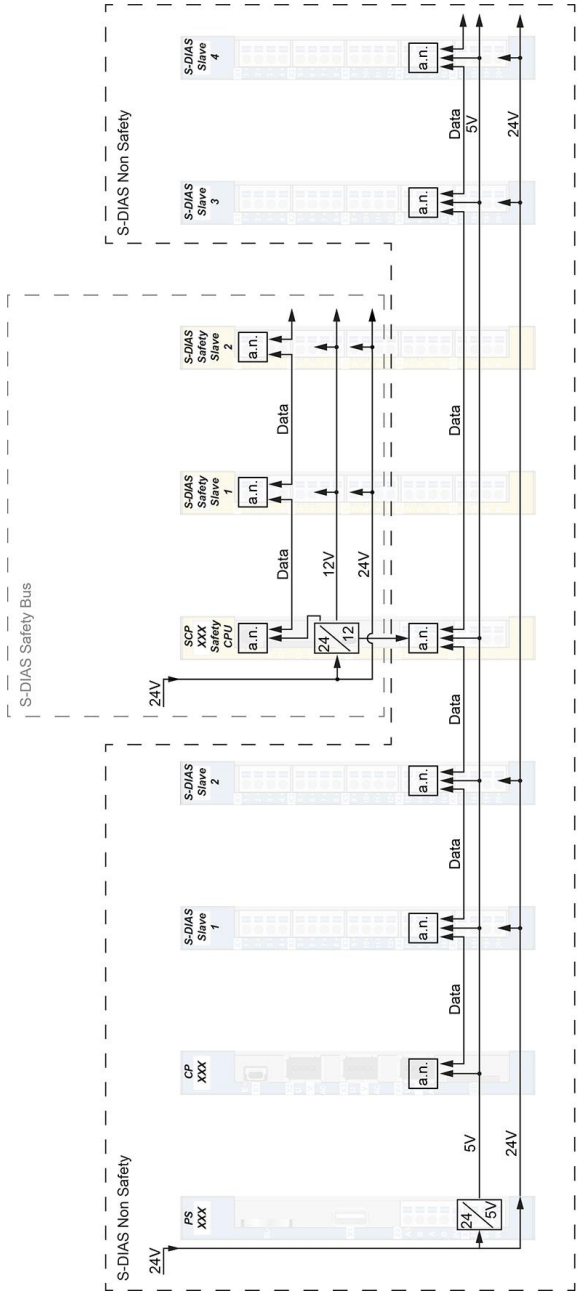

Wiring S-DIAS Safety in S-DIAS System

a.n. = active node

- each S-DIAS module is an active module (active node)
- Safety CPU is connected to the S-DIAS bus (incl. +5 V supply)
- Safety bus is independent and separated from the S-DIAS bus

## 5.5 Miscellaneous

Article number	20-064-041
Standard	UL 508 (E247993)
Approbations	UL, cUL, CE, UKCA

## 5.6 Environmental Conditions

Storage temperature	-40 ... +85 °C	
Environmental temperature	-25 ... +60 °C	
Humidity	0-95 %, non-condensing	
Installation altitude above sea level	0-2000 m without derating > 2000 m up to a maximum of 5000 m with derating of the maximum environmental temperature by 0.5 °C per 100 m	
Operating conditions	Pollution degree 2	
EMC resistance	in accordance with EN 61000-6-2 (industrial area)	
EMC noise generation	in accordance with EN 61000-6-4 (industrial area)	
Vibration resistance	EN60068-2-6	3.5 mm from 5-8.4 Hz 1g from 8.4-150 Hz
Shock resistance	EN 60068-2-27	15 g
Protection type	EN 60529	IP20

## 6 Mechanical Dimensions

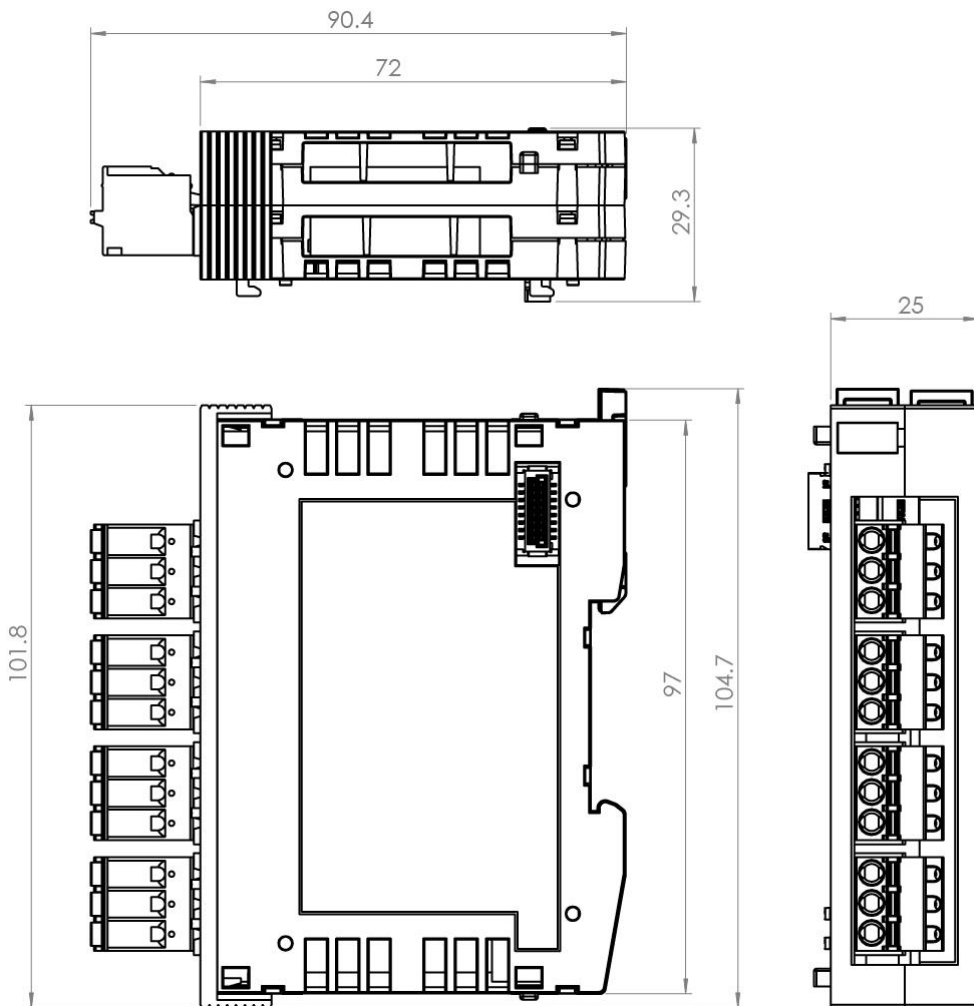

## 7 Connector Layout

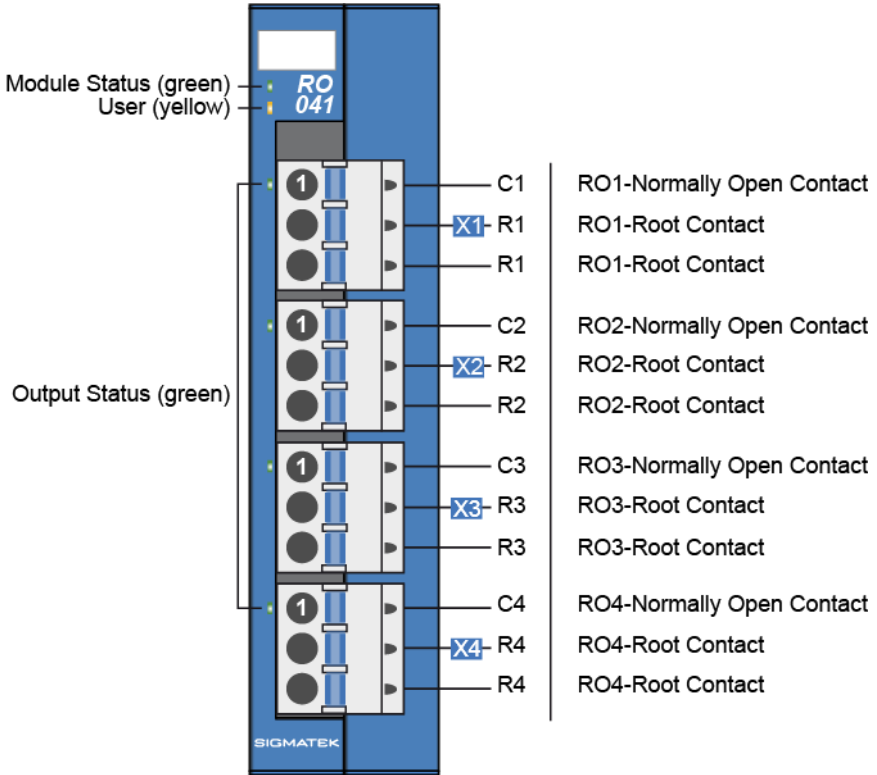

### 7.1 Status LEDs

Module Status	green	ON	module active
		OFF	no supply available
		BLINKING (5 Hz)	no communication
User	yellow	ON	can be set from the application
		OFF	(e.g. the module LED can be set to blinking through the visualization so that the module is easily found in the control cabinet)
		BLINKING (2 Hz)	
		BLINKING (4 Hz)	
Output status	green	ON	output on
		OFF	output off

## 7.2 Applicable Connectors

### Connectors:

**X1-X4:** Connectors with spring terminals (included in delivery)

The spring terminals are suitable connecting ultrasonically compacted (ultrasonically welded) strands.

### Connections:

Stripping length/Sleeve length:	10 mm
Plug-in direction:	parallel to conductor axis or to parallel to PCB
Conductor cross section, rigid:	0.2-2.5 mm <sup>2</sup>
Conductor cross section, flexible:	0.2-2.5 mm <sup>2</sup>
Conductor cross section, ultrasonically compacted:	0.2-2.5 mm <sup>2</sup>
Conductor cross section AWG/kcmil:	24-12
Conductor cross section flexible, with ferrule without plastic sleeve:	0.25-2.5 mm <sup>2</sup>
Conductor cross section flexible, with ferrule with plastic sleeve:	0.25-2.5 mm <sup>2</sup>

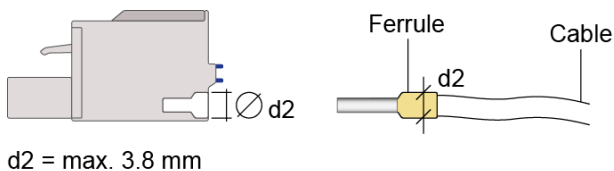

### 7.3 Label Field

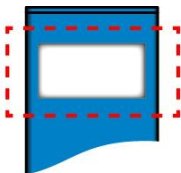

Manufacturer	Weidmüller
Type	MF 10/5 CABUR MC NE WS
Weidmüller article number	1854510000
Compatible printer	Weidmüller
Type	Printjet Advanced 230V
Weidmüller article number	1324380000

## 8 Wiring

### 8.1 Wiring Example

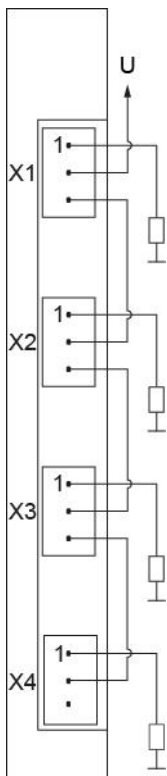

## 8.2 Note

The input filters, which suppress noise signals, allow operation in harsh environmental conditions. A careful wiring method is also recommended to ensure error-free function.

The following guidelines should be observed:

- Avoid parallel connections between input lines and load-bearing circuits.
- protective circuits for all relays (RC networks or free-wheeling diodes).
- correct wiring to ground.

### INFORMATION



The ground bus should be connected to the control cabinet when possible!

The S-DIAS module cannot be connected or disconnected while voltage is applied!

## 9 Assembly/Installation

### 9.1 Check Contents of Delivery

Ensure that the contents of the delivery are complete and intact. See chapter 1.3 Contents of Delivery.

#### INFORMATION



On receipt and before initial use, check the device for damage. If the device is damaged, contact our customer service and do not install the device in your system.

Damaged components can disrupt or damage the system.

## 9.2 Mounting

The S-DIAS modules are designed for installation into the control cabinet. To mount the modules a DIN-rail is required. The DIN rail must establish a conductive connection with the back wall of the control cabinet. The individual S-DIAS modules are mounted on the DIN rail as a block and secured with latches. The functional ground connection from the module to the DIN rail is made via the grounding clamp on the back of the S-DIAS modules. The modules must be mounted horizontally (module label up) with sufficient clearance between the ventilation slots of the S-DIAS module blocks and nearby components and/or the control cabinet wall. This is necessary for optimal cooling and air circulation, so that proper function up to the maximum operating temperature is ensured.

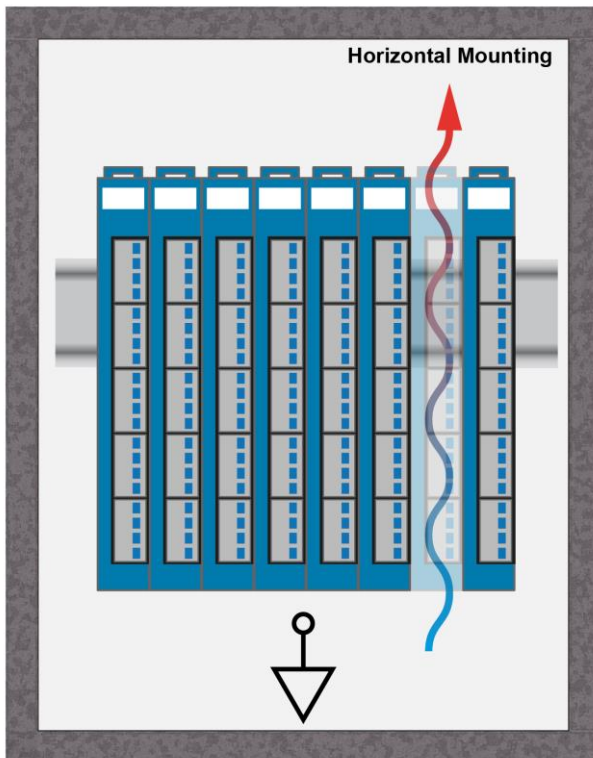

Recommended minimum distances of the S-DIAS modules to the surrounding components or control cabinet wall:

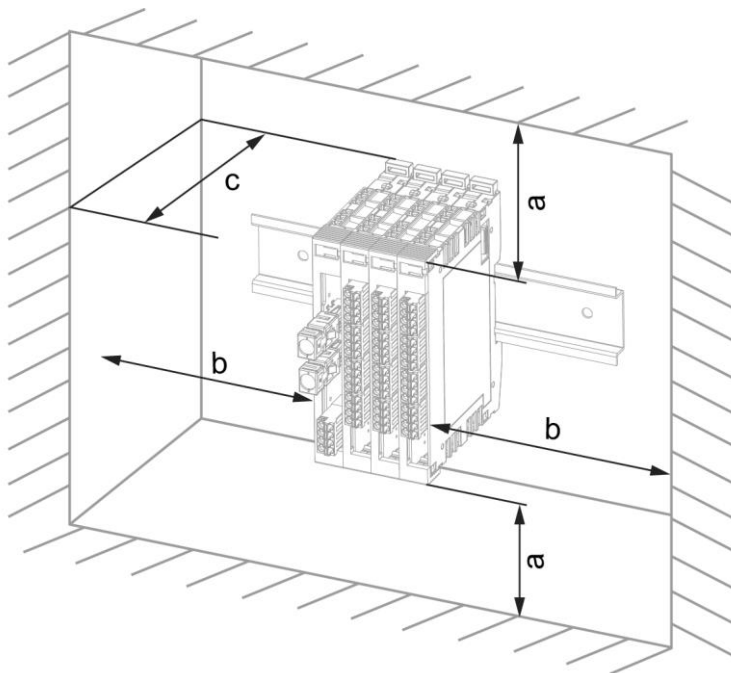

a	b	c
30 mm (1.18")	30 mm (1.18")	100 mm (3.94")

a, b, c ... distances in mm (inches)

## 10 Transport/Storage

### INFORMATION



This device contains sensitive electronics. During transport and storage, high mechanical stress must therefore be avoided.

For storage and transport, the same values for humidity and vibration as for operation must be maintained!

Temperature and humidity fluctuations may occur during transport. Ensure that no moisture condenses in or on the device, by allowing the device to acclimate to the room temperature while turned off.

When sent, the device should be transported in the original packaging if possible. Otherwise, packaging should be selected that sufficiently protects the product from external mechanical influences. Such as cardboard filled with air cushioning.

## 11 Storage

### INFORMATION



When not in use, store the operating panel according to the storage conditions. See chapter 10.

During storage, ensure that all protective covers (if available) are placed correctly, so that no contamination, foreign bodies or fluids enter the device.

## 12 Maintenance

### INFORMATION



During maintenance as well as servicing, observe the safety instructions from chapter 2 Basic Safety Directives.

### 12.1 Service

This product was constructed for low-maintenance operation.

### 12.2 Repair

### INFORMATION



In the event of a defect/repair, send the device with a detailed error description to the address listed at the beginning of this document.

For transport conditions, see chapter 10 Transport/Storage.

## 13 Disposal

### INFORMATION



Should you need to dispose of the device, the national regulations for disposal must be followed.

The device appliance must not be disposed of as household waste.



## 14 Addressing

Address (hex)	Size (bytes)	Access Type	Description	Reset Value
<b>Memory</b>				
0000	1	w	Output register Bit 0 Output 1-Relay 1 Bit 1 Output 2-Relay 2 Bit 2 Output 3-Relay 3 Bit 3 Output 4-Relay 4 Bit 4-7 Reserved	0000
0002	1	r	24 V Status Bit 0 DC 24V OK Bit 1-7 Reserved	0000

## 15 Supported Cycle Times

### 15.1 Cycle Times below 1 ms (in $\mu\text{s}$ )

50	100	125	200	250	500
x	x	x	x	x	x

x= supported

### 15.2 Cycle Times equal to or higher than 1 ms (in ms)

1	2	3	4	5	6	7	8	9	10	11	12	13	14	15	16
x	x	x	x	x	x	x	x	x	x	x	x	x	x	x	x

x= supported

17	18	19	20	21	22	23	24	25	26	27	28	29	30	31	32
x	x	x	x	x	x	x	x	x	x	x	x	x	x	x	x

x= supported

## 16 Hardware Class RO041

### Hardware Class RO041 for the RO041 S-DIAS digital module

```
SDIAS:57, RO041 (R00411)
  S Class State (ClassState) <-[]->
  S Device ID (DeviceID) <-[]->
  S FPGA Version (FPGAVersion) <-[]->
  S Hardware Version (HwVersion) <-[]->
  S Serial Number (SerialNo) <-[]->
  S Retry Counter (RetryCounter) <-[]->
  O LED Control (LEDControl) <-[]->
  ----- Digital Outputs -----
  O Digital Out 1 (Output1) <-[]->
  O Digital Out 2 (Output2) <-[]->
  O Digital Out 3 (Output3) <-[]->
  O Digital Out 4 (Output4) <-[]->
  S Voltage OK Output 1-4 (VoltageOk) <-[]->
  ALARM:00, Empty
```

This hardware class is used to control the RO 041 hardware module with 4 inputs. More information on the hardware can be found in the module documentation.

## 16.1 Interfaces

### 16.1.1 Clients

<b>SdiasIn</b>	The client must be connected to an S-DIAS port, an "SdiasOut"_[x]" server.
<b>Place</b>	The physical location of the hardware module is entered in this client. Up to 64 modules, 0 to 63, can be assigned.
<b>Required</b>	This client is active by default, which means that the S-DIAS hardware module at this position is mandatory for the system and can under no circumstances be disconnected or return an error. Otherwise, the entire hardware deactivated. If the hardware module is missing or removed, an S-DIAS error is triggered. If his client is initialized with 0, the hardware module located in this position is not mandatory. This means that it doesn't have to be available or error-free. However, which components identified as "not required" should be selected with regard to the safety of the system.

### 16.1.2 Servers

<b>ClassState</b>	This server shows the actual status of the hardware class.								
<b>DeviceID</b>	The device ID of the hardware module is shown in this server.								
<b>FPGAVersion</b>	FPGA version of the module in 16#XY (e.g. 16#10 = version 1.0).								
<b>SerialNo</b>	The serial number of the hardware module is shown in this server.								
<b>RetryCounter</b>	This server increments when a transfer fails.								
<b>LEDControl</b>	With this server, the application LED of the S-DIAS module can be activated to find the module in the network more quickly. The following statuses are possible: <table border="1" style="width: 100%; margin-top: 5px;"> <tr> <td>0</td> <td>LED off</td> </tr> <tr> <td>1</td> <td>LED on</td> </tr> <tr> <td>2</td> <td>blinks slowly</td> </tr> <tr> <td>3</td> <td>blinks rapidly</td> </tr> </table>	0	LED off	1	LED on	2	blinks slowly	3	blinks rapidly
0	LED off								
1	LED on								
2	blinks slowly								
3	blinks rapidly								
<b>Output[1-4]</b>	Output set via the write() method.								
<b>OutputByte</b>	In this server, the digital outputs are shown in a bit field. In this 4-byte value, bits 0 to 3 are allocated to output1 to output4. A write() instruction to this server writes the bit pattern to these outputs.								
<b>VoltageOk</b>	<table border="1" style="width: 100%; margin-top: 5px;"> <tr> <td>0</td> <td>power supply error</td> </tr> <tr> <td>1</td> <td>Supply OK for outputs 1-4</td> </tr> </table>	0	power supply error	1	Supply OK for outputs 1-4				
0	power supply error								
1	Supply OK for outputs 1-4								

### 16.1.3 Communication Interfaces

<b>ALARM</b>	Downlink	With this downlink the corresponding alarm class can be placed via the hardware editor.
--------------	----------	---

## 16.2 Example

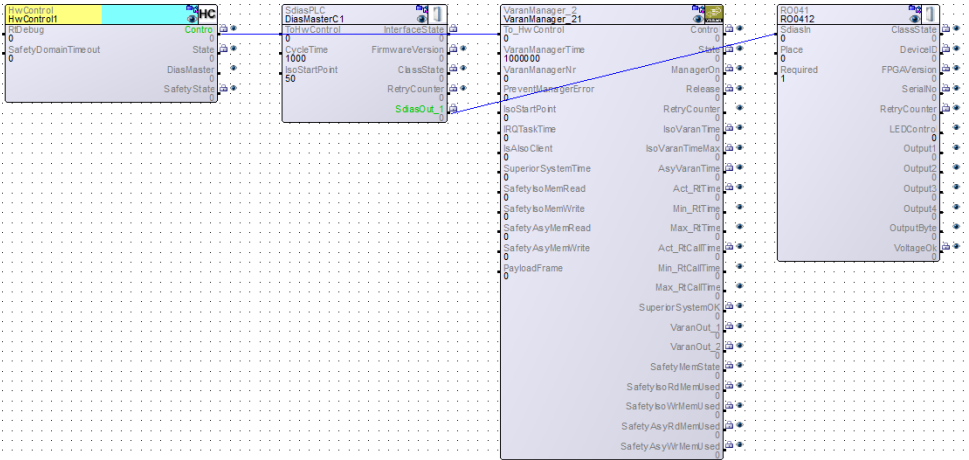

## Documentation Changes

Change date	Affected page(s)	Chapter	Note
30.01.2014	11	4.2 Note	Note regarding the connection/disconnection of the S-DIAS module under voltage added.
11.02.2015	Page 1 Page 3 Page 8 Page 10	S-DIAS Relay Output Module RO 21 1.1 Relay output specifications 3 Connector LEDs 4 Wiring	Start sentence changed (von 230V/3 A or 24V/3 A in 230V/6 A AC or 24 V/6 A DC) Relay output specifications table: Rated voltage, maximum allowable continuous current/channel, simultaneity of all outputs, maximum allowable continuous current per contact, on and off delay, switch voltage Changed pin assignment Changed plugging diagrams
31.08.2015	Page 5	1.4 Electrical Requirements	Supply voltage corrected
08.09.2015	Page 3 Page 4	1.1 Relay Output Specifications 1.2 Relay Data	Added Relay type in table Changed headline to Relay Data V23061-A1007-A302
21.01.2016	Page 6	1.5 Miscellaneous	Standard changed
26.01.2016	5	1.4 Electrical Requirements	Graphic added
28.04.2016	15	5 Mounting	Graphics distances
17.08.2017	8 11	1.6 Environmental Conditions 3.2 Applicable Connectors	Added operating conditions Added sleeve length Added info regarding ultrasonically welded strands
18.10.2017	12 16	3.3 Label Field 5 Mounting	Added chapter Graphic replaced
14.11.2019	18	7 Supported Cycle Times	Chapter added
28.02.2020	18	7 Supported Cycle Times	Text adapted
08.09.2020	19	8 Hardware Class RO041	Chapter added
04.11.2020	15	5 Mounting	Expansion functional ground connection
06.12.2022	8	1.5 Miscellaneous	UKCA conformity
26.07.2023		Document	General chapters added, design