

SCP 211

S-DIAS Safety CPU Module

Instruction Manual

Publisher: SIGMATEK GmbH & Co KG
A-5112 Lamprechtshausen
Tel.: +43/6274/4321
Fax: +43/6274/4321-18
Email: office@sigmatek.at
WWW.SIGMATEK-AUTOMATION.COM

Copyright © 2021
SIGMATEK GmbH & Co KG

Translation of the Original Instruction

All rights reserved. No part of this work may be reproduced, edited using an electronic system, duplicated or distributed in any form (print, photocopy, microfilm or in any other process) without express permission.

We reserve the right to make changes in the content without notice. SIGMATEK GmbH & Co KG is not responsible for technical or printing errors in this handbook and assumes no responsibility for damages that occur through its use.

S-DIAS Safety CPU Module

SCP 211

The S-DIAS Safety CPU module SCP 211 supports up to 16 Safe I/O modules. In addition, the SCP 211 can operate handheld devices with an emergency stop switch, as well as confirmation and key switches.

The Safety CPU component has the safety integrity level **SIL3** (EN IEC 62061) or **Performancelevel e** (PL e) **Category 4** (EN ISO 13849).

The safety-related SCP 211 is ideal for use in systems with optional modules and interface variables according to the system Manual see Homepage¹.

The SCP 211 alone is already a minimal system of a safety control.

In addition, the Safety SCP 211 regulates the synchronized communication with the remote safety modules through safe bus telegrams. Among their jobs are:

- Processing the safe application and
- The distribution of configuration data to remote safety modules



¹ Using the search function with the keyword "Safety System Manual"

Contents

1	Introduction	6
1.1	Target Group/Purpose of this Operating Manual	6
1.2	Important Reference Documentation	6
1.3	Contents of Delivery	6
2	Basic Safety Guidelines	7
2.1	Symbols Used	7
2.2	Disclaimer	9
2.3	General Safety Directives	10
2.4	Designated Use	12
2.5	Software/Training	13
3	IT Security	14
4	Standards and Directives	15
4.1	Residual Risks	15
4.2	Safety of the Machine or Equipment	15
4.3	Directives	15
4.3.1	Functional Safety Standards	16
4.3.2	EU Conformity Declaration	16
4.5	Safety-Relevant Parameters	17
4.6	Compatibility	17
5	Type Plate	18

6	Technical Data	19
6.1	Performance Data	19
6.2	Electrical Requirements	20
6.2.1	Module Supply (Input)	20
6.2.2	S-DIAS Bus/Safety Supply (Output)	21
6.3	Miscellaneous	23
6.4	Environmental Conditions	23
7	Mechanical Dimensions	24
8	Connector Layout	25
8.1	Status LEDs	26
8.2	Applicable Connectors	27
8.3	Label Field	28
9	Validation Button	29
9.1	Explanation of the individual sequences	29
9.1.1	Start Sequence	29
9.1.2	Command Selection Sequence	30
9.1.3	End Sequence	30
9.1.4	Error Sequence	31
9.2	Overview of Commands	32
9.3	Overview of Module Statuses and Commands	32
9.4	Handling the microSD Card (mSD)	34
9.5	Configuring a Safety CPU with the mSD Card	35

10	Response to Errors	36
10.1	Restart Errors.....	36
10.2	Configuration Distribution Error	37
10.3	Troubleshooting	38
10.4	Troubleshooting with the SAFETYDesigner	38
10.5	Correcting a Wiring Error.....	38
11	Wiring Guidelines	39
11.1	Shielding.....	40
11.2	ESD Protection.....	40
12	Assembly/Installation	41
12.1	Check Contents of Delivery	41
12.2	Mounting.....	42
13	Supported Cycle Times	44
13.1	Cycle Times below 1 ms (in μ s).....	44
13.2	Cycle Times equal to or higher than 1 ms (in ms).....	44
14	Transport/Storage.....	45
15	Storage	45
16	Maintenance	46
16.1	Service	46
16.2	Repair.....	46

17 Disposal 46

1 Introduction

1.1 Target Group/Purpose of this Operating Manual

This operating manual contains all information required for the operation of the product.

This operating manual is intended for:

- Project planners
- Technicians
- Commissioning engineers
- Machine operators
- Maintenance/test technicians

General knowledge of automation technology is required.

Further help and training information, as well as the appropriate accessories can be found on our website www.sigmatek-automation.com.

Our support team is happily available to answer your questions.
Please see our website for our hotline number and business hours.

1.2 Important Reference Documentation

- Safety System Handbook

This and additional documents can be downloaded from our website or obtained through support.

1.3 Contents of Delivery

1x SCP 211

2 Basic Safety Guidelines

2.1 Symbols Used

The following symbols are used in the operator documentation for warning and danger messages, as well as informational notes:

DANGER



Danger indicates that death or serious injury **will occur**, if the specified measures are not taken.

⇒ To avoid death or serious injuries, observe all guidelines.

Danger indique une situation dangereuse qui, faute de prendre les mesures adéquates, **entraînera** des blessures graves, voire mortelles.

⇒ Respectez toutes les consignes pour éviter des blessures graves, voire mortelles.

WARNING



Warning indicates that death or serious injury **can** occur, if the specified measures are not taken.

⇒ To avoid death or serious injuries, observe all guidelines.

Avertissement d'une situation dangereuse qui, faute de prendre les mesures adéquates, **entraînera** des blessures graves, voire mortelles.

⇒ Respectez toutes les consignes pour éviter des blessures graves, voire mortelles.

CAUTION



Caution indicates that moderate to slight injury **can** occur, if the specified measures are not taken.

⇒ To avoid moderate to slight injuries, observe all guidelines.

Attention indique une situation dangereuse qui, faute de prendre les mesures adéquates, **peut** entraîner des blessures assez graves ou légères.

⇒ Respectez toutes les consignes pour éviter des blessures graves, voire mortelles.

CAUTION

Danger for ESD-sensitive components.

Les signes de danger pour les composants sensibles aux décharges électrostatiques.

INFORMATION**Information**

- ⇒ Provides important information on the product, handling or relevant sections of the documentation, which require attention.

2.2 Disclaimer

INFORMATION



The contents of this operating manual were prepared with the greatest care. However, deviations cannot be ruled out. This operating manual is regularly checked and required corrections are included in the subsequent versions. The machine manufacturer is responsible for the proper assembly, as well as device configuration. The machine operator is responsible for safe handling, as well as proper operation.

The current operating manual can be found on our website. If necessary, contact our support.

Subject to technical changes, which improve the performance of the devices. The following operating manual is purely a product description. It does not guarantee properties under the warranty.

Please thoroughly read the corresponding documents and this operating manual before handling a product.

SIGMATEK GmbH & Co KG is not liable for damages caused through, non-compliance with these instructions or applicable regulations.

2.3 General Safety Directives

The Safety Directives in the other sections of this operating manual must be observed. These instructions are visually emphasized by symbols.

INFORMATION



According to EU Directives, the operating manual is a component of a product.

This operating manual must therefore be accessible in the vicinity of the machine since it contains important instructions.

This operating manual should be included in the sale, rental or transfer of the product, or its online availability indicated.

Regarding the requirements for Safety and health connected to the use of machines, the manufacturer must perform a risk assessment in accordance with machine directives 2006/42/EG before introducing a machine to the market.

Operate the unit with devices and accessories approved by SIGMATEK only.

CAUTION

Handle the device with care and do not drop or let fall.
Prevent foreign bodies and fluids from entering the device.
The device must not be opened!

Manipulez l'appareil avec précaution et ne le laissez pas tomber.
Empêchez les corps étrangers et les liquides de pénétrer dans l'appareil.

L'appareil ne doit pas être ouvert!

If the device does not function as intended or has damage that could pose a danger, it must be replaced!

En cas de fonctionnement non conforme ou de dommages pouvant entraîner des risques, l'appareil doit être remplacé!

The module complies with EN 61131-2.

In combination with a facility, the system integrator must comply with EN 60204-1 standards.

For your own safety and that of others, compliance with the environmental conditions is essential.

Le module est conforme à la norme EN 61131-2.

En combinaison avec une équipement, l'intégrateur de système doit respecter la norme EN 60204-1.

Pour votre propre sécurité et celle des autres, le respect des conditions environnementales est essentiel.

2.4 Designated Use

The Safety functions implemented in the product are designed for use with safety applications in a PLC control and meet the required conditions for safe operation according to SIL 3, HFT 1 n compliance with EN IEC 62061 and according to PL e, Kat. 4 in compliance with EN ISO 13849-1.

CAUTION



The instructions contained in this operating manual must be followed.

For error-free operation, proper transport and storage are essential.

Installation, mounting, programming, initial start-up, operation, maintenance and decommissioning can only be performed by qualified personnel.

Qualified personnel in this context are people, who have completed training or have trained under supervision of qualified personnel and have been authorized to operate and maintain safety-related equipment, systems and facilities in compliance with the strict directives and standards of safety technology (Functional Safety).

Les instructions contenues dans ce manuel technique doivent être suivies.

Pour un fonctionnement sans erreur, le transport et le stockage appropriés sont essentiels.

L'installation, le montage, la programmation, la mise en service initiale, l'exploitation, la maintenance et la mise hors service ne peuvent être effectués que par une personne qualifiée.

Dans ce contexte, on entend par personnel qualifié les personnes qui ont suivi une formation ou qui ont été formées sous la supervision d'un personnel qualifié et qui ont été autorisées à utiliser et à entretenir l'équipement, les systèmes et les installations de sécurité conformément aux directives et aux normes strictes de la technique de sécurité (Sécurité fonctionnelle).

For your own safety and that of others, the product should be used for their designated purpose only.

Correct EMC installation is also included under designated use.

Pour votre propre sécurité et celle des autres, le produit ne doivent être utilisés qu'à des fins prévues.

Une installation CEM correcte est également incluse dans l'utilisation

prévue.

Non-designated use consists of:

- any changes made to the module or the use of damaged modules.
- use of the module inconsistent with the technical margins described in this operating manual or the specifications defined in the technical data.

L'utilisation non désignée consiste en:

- toute modification apportée au module ou l'utilisation des modules endommagés.
- utilisation du module non conforme aux marges techniques décrites dans ce manuel ou aux spécifications définies dans les données techniques.

Before delivering the module, the machine manufacturer must ensure that it is in "delivery condition". See chapter Transport/Storage for more information.

Avant de livrer le module, le constructeur de la machine doit s'assurer qu'il est en "état de livraison". Voir le chapitre Transport/Storage pour plus d'informations.

2.5 Software/Training

The application is created with the software LASAL CLASS 2 and LASAL SCREEN Editor, the Safety application is created using the SAFETYDesigner. Basic information on Safety (Functional Safety) can be found in the Safety System Handbook.

Training for the LASAL development environment, with which the product can be configured, is provided. Information on our training schedule can be found on our website.

3 IT Security

S-DIAS safety modules were developed for integration into a network protected against unauthorized access. For example, the following dangers can affect the network:

- Unauthorized access
- Data manipulation
- and many other IT security violations

It is the responsibility of the operator to protect the safe connection between S-DIAS modules against unauthorized access. The following measures, for example, are suitable for this:

- Firewalls
- Password-protected user accounts
- Data encryption
- and much more

4 Standards and Directives

4.1 Residual Risks



CAUTION

The following residual risks for the product must be included in the system integrator's risk assessment:

- Release of non-environmentally safe substances, emissions and unusual temperatures
- Possible effects of information technology devices

Les risques résiduels suivants pour le produit doivent être inclus dans l'évaluation des risques de l'intégrateur de système:

- Libération de substances non respectueuses de l'environnement, émissions et températures inhabituelles
- Effets possibles des dispositifs de technologie de l'information

4.2 Safety of the Machine or Equipment



INFORMATION

Observe all on-site rules and regulations for accident prevention and occupational safety.

4.3 Directives

The product was constructed in compliance with the following European Union directives and tested for conformity.

4.3.1 Functional Safety Standards

EN IEC 62061 - Safety of machinery - Functional safety of safety-related control systems
EN ISO 13849-1 - Safety of machinery - Safety-related parts of control systems - Part 1: General principles for design
EN ISO 13849-2 - Safety of machinery - Safety-related parts of control systems - Part 2: Validation

4.3.2 EU Conformity Declaration



EU Declaration of Conformity

The product SCP 211 conforms to the following European directives:

- **2006/42/EG** Machine Directive
- **2014/30/EU** Electromagnetic Compatibility (EMC Directive)
- **2011/65/EU** "Restricted use of certain hazardous substances in electrical and electronic equipment" (RoHS Directive)

The EU Conformity Declarations are provided on the SIGMATEK website. They can be found in the download area of the respective product.

4.5 Safety-Relevant Parameters

CPU Module	Safety Parameters	Safety Level
SCP 211	PFH = 2.00E-9 MTTF _D = 1099 years DC = 99 % SFF = 99 %	SIL 3 according to EN IEC 62061 PL e / Cat. 4 According to EN ISO 13849

Assembly: Two-channel redundant (diverse)

4.6 Compatibility

INFORMATION



For compatibility of the S-DIAS Safety modules, see section "Compatibility of S-DIAS Safety Modules" in the system handbook.

5 Type Plate

	HW: X.XX
	SW: XX.XX.XXX
	Safety Version: SXX.XX.XX
Serial No.	SIGMATEK GMBH & CO KG Sigmatekstrasse 1 A-5112 LAMPRECHTSHAUSEN
Article Number	Product Name Short Name

Exemplary nameplate (symbol image)

	HW: 1.00
	SW: 01.00.000
	Safety Version: S01.00.00
12345678	SIGMATEK GMBH & CO KG Sigmatekstrasse 1 A-5112 LAMPRECHTSHAUSEN
12-246-133-3	Handbediengerät Wireless HGW 1033-3

HW: Hardware version

SW: Software version

6 Technical Data

6.1 Performance Data

CPU	ARM Cortex M μ Controller	
Addressable Safety I/O modules	S-DIAS Safety bus: 16	
Data memory	Type	SRAM
	Memory	500 kbytes
Program memory	Type	Flash
	Memory	1 Mbyte
Remnant memory for parameter lists	Type	SPI-Flash
	Memory	64 kbytes
	Life span	min. 100.000x write access
Remnant memory for variables	Type	EERAM
	Memory	1000 byte
Interfaces	1x microSD card holder for microSD card for loading Safety projects to the Safety CPU 1x Safety interface, Phoenix MC1.5/3-G-3.5 1x USB device type B Mini (online & programming interface) 1x S-DIAS IN/OUT 1x Safety bus OUT	
Bus connection possible	yes	
Status LEDs	yes	

6.2 Electrical Requirements

6.2.1 Module Supply (Input)

Supply voltage	+19.2-28.8 V DC, typically +24 V DC SELV/PELV ¹⁾				
Current consumption, internal usage	typically, 90 mA (internal demand)				
	maximal 2.4 A ^{2), 3)}				
The supply is from the S-DIAS bus.		+5 V		+24 V	
	with missing +24 V connection (X3)	typically, 250 mA	maximum 300 mA	0 A	0 A
	with available +24 V connection (X3)	0 A	0 A	0 A	0 A

INFORMATION



A supply voltage fuse with sufficient voltage and current limiting must be provided!

6.2.2 S-DIAS Bus/Safety Supply (Output)

Current Supply	in the S-DIAS bus	+5 V	+24 V
		0 A	0 A
	in the S-DIAS safety bus (I/O module supply)	+12 V	+24 V
		max. 0.8 A ^{2), 4)}	max. 1.6 A ^{2), 4)}

INFORMATION



⁽¹⁾ For USA and Canada:

The supply must be limited to:

- a) max. 5 A at voltages from 0-20 V DC, or
- b) 100 W at voltages from 20-60 V DC.

The limiting component (e.g. transformer, power supply or fuse) must be certified by an NRTL (Nationally Recognized Testing Laboratory).

²⁾ Dependent on the number of modules connected on the S-DIAS Safety bus

³⁾ For loading the internal capacitors, power consumption may be increased for a short time (in the microsecond range). This value is dependent on the input voltage and impedance of the power source

⁴⁾ If this S-DIAS Safety module is operated with several modules, the total current of the S-DIAS Safety modules used must be determined and checked!

The total current of the +24 V supply cannot exceed 1600 mA.
 The total current of the +12 V supply cannot exceed 800 mA.

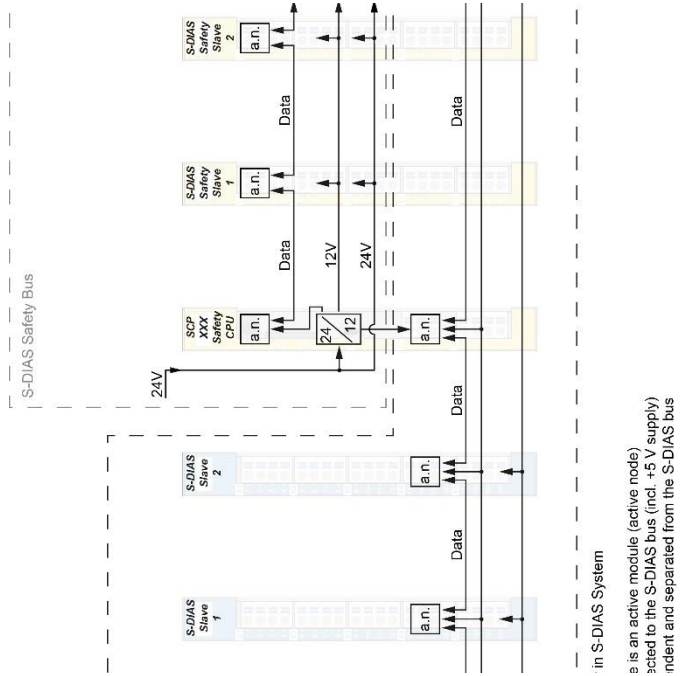

6.3 Miscellaneous

Article number	20-890-211
Approvals	CE, TÜV EG type tested
Mission time	20 years

6.4 Environmental Conditions

Storage temperature	-20 ... +85 °C	
Environmental temperature	0 ... +60 °C	
Humidity	0-95 %, non-condensing	
Installation altitude above sea level	0-2000 m without derating > 2000 m up to a maximum of 5000 m with derating of the maximum environmental temperature by 0.5 °C per 100 m	
Operating conditions	pollution degree 2 indoor use only	
Noise emissions	≤ 70 dB	
EMC resistance	in accordance with EN 61000-6-7 (Generic standards – immunity requirements for equipment designed to perform functions in safety-based systems (functional safety) at industrial facilities) according to EN 61000-6-2 (industrial area) (increased requirements in accordance with EN IEC 62061)	
EMC noise generation	in accordance with EN 61000-6-4 (industrial area)	
Vibration resistance	EN 60068-2-6	3.5 mm from 5-8.4 Hz 1 g from 8.4-150 Hz
Shock resistance	EN 60068-2-27	15 g
Protection type	EN 60529	IP20

7 Mechanical Dimensions

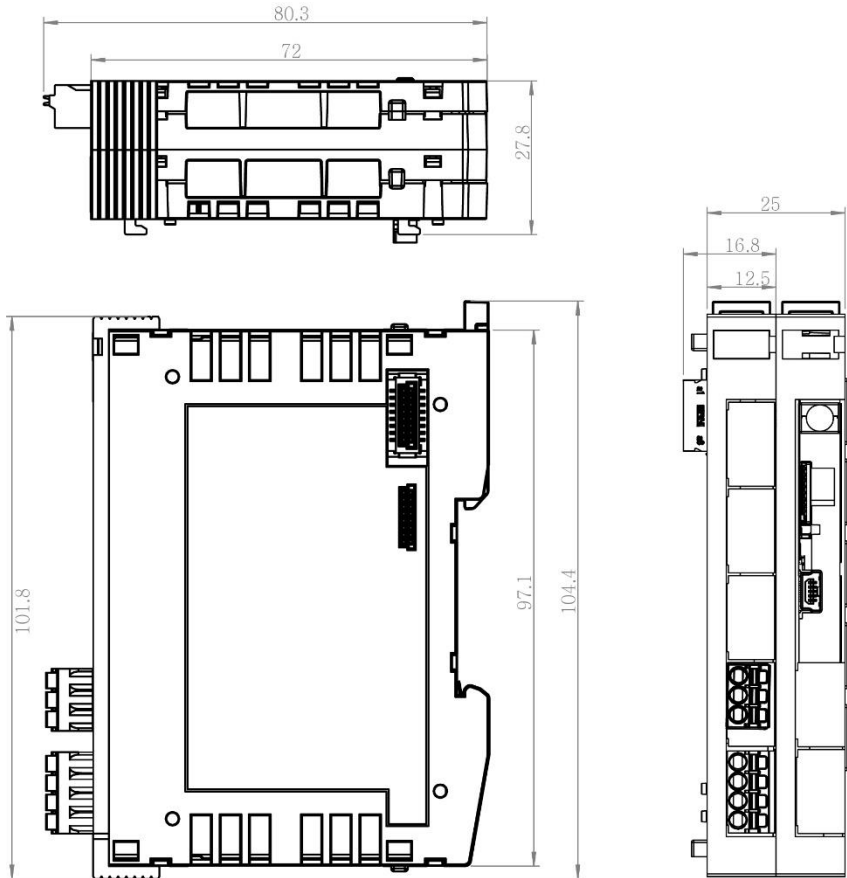

8 Connector Layout

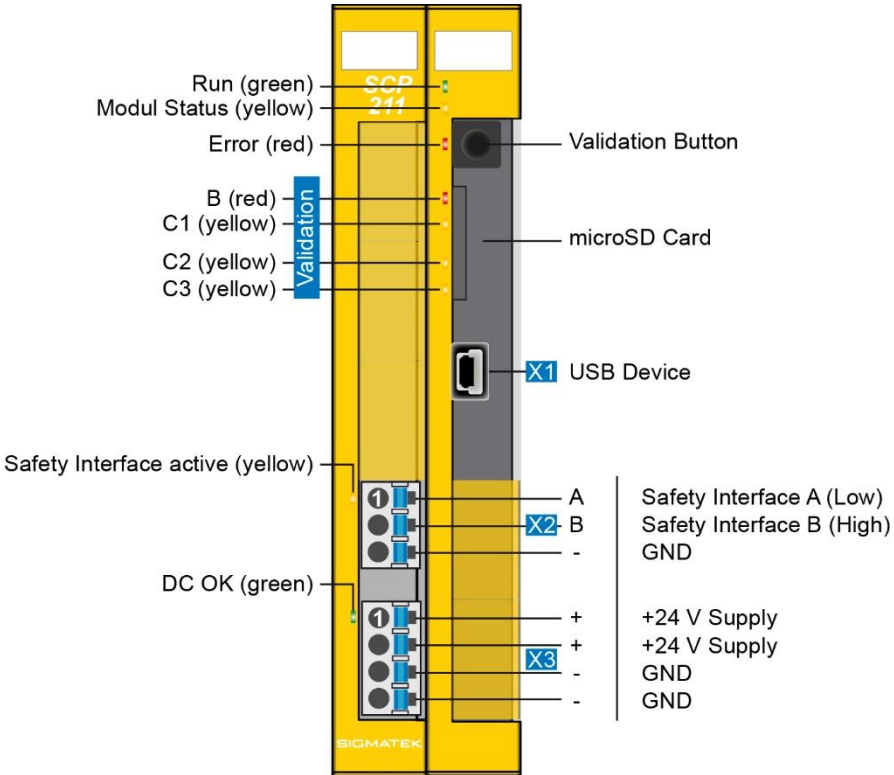

INFORMATION



The connections of the +24 V supply (X3: pin 1 and pin 2) or the GND supply (X3: pin 3 and pin 4) are internally bridged. To supply the module, only one connection to a +24 V pin (pin 1 or pin 2) and a GND pin (pin 3 or pin 4) is required. The bridged connections may be used for further looping of the +24 V supply and the GND supply. However, it must be taken into account that a total current of 6 A per connection is not exceeded by the forward looping!

8.1 Status LEDs

The LED display lights continuously to indicate that the in- and outputs are active.

Run	green	Run	Indicates <ul style="list-style-type: none"> - The time-limited (LED "S" on) operation mode or - or unlimited time ("S" LED off) operation mode.
Module Status	yellow	status	<ul style="list-style-type: none"> - Lights permanently: the module is in service mode - Slow blinking frequency: the module is currently in Idle or Check Configuration mode (distribution of the configuration)
Error	red	Error	<ul style="list-style-type: none"> - Lights permanently: the module is in error mode - Slow blinking frequency: the maximum age has been exceeded for a removed input (can be read with the SAFETYDesigner) - Fast blinking frequency: serious error; communication with the module is no longer possible (CANNOT be read with the SAFETYDesigner)
B	red	Display validation button S1	See chapter "Validation Button" for description
C1	yellow	Command 1	See chapter "Validation Button" for description
C2	yellow	Command 2	See chapter "Validation Button" for description
C3	yellow	Command 3	See chapter "Validation Button" for description
Safety interface inactive	yellow	Safety interface connection	Indicates an active Safety interface
DC OK	green	DC OK +24 V	Signals the availability of the supply voltage

8.2 Applicable Connectors

Connectors:

X1: USB Type Mini-B (not included with delivery)

X2, X3: Connectors with spring terminals (included with delivery)

The spring terminals are suitable for the connection of ultrasonically compressed (ultrasonically welded) strands.

Connections:

Stripping length/sleeve length:	10 mm
Mating direction:	parallel to the conductor axis or circuit board
Conductor cross section rigid:	0.2-1.5 mm ²
Conductor cross section flexible:	0.2-1.5 mm ²
Conductor cross-section strands ultrasonically compacted:	0.2-1.5 mm ²
Conductor cross section AWG/kcmil:	24-16
Conductor cross section flexible with ferrule without plastic sleeve:	0.25-1.5 mm ²
Conductor cross section flexible with ferrule with plastic sleeve:	0.25-0.75 mm ² (reason for reduction d2 of the ferrule)

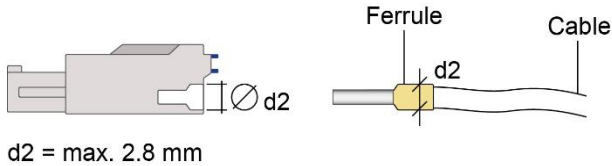

8.3 Label Field

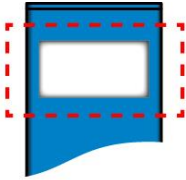

Manufacturer	Weidmüller
Type	MF 10/5 CABUR MC NE WS
Article number Weidmüller	1854510000
Compatible printer	Weidmüller
Type	Printjet Advanced 230V
Article number Weidmüller	1324380000

9 Validation Button

With the validation button S1, several commands as well as the validation can be executed:

- Acknowledging an error and exiting the error status
- Deleting a configuration in the Safety CPU
- Validation of the configured safety system

Inputting commands with the validation button consists of 3 sequential components; the start and End sequence, and the sequence for selecting a command (see the following diagram).

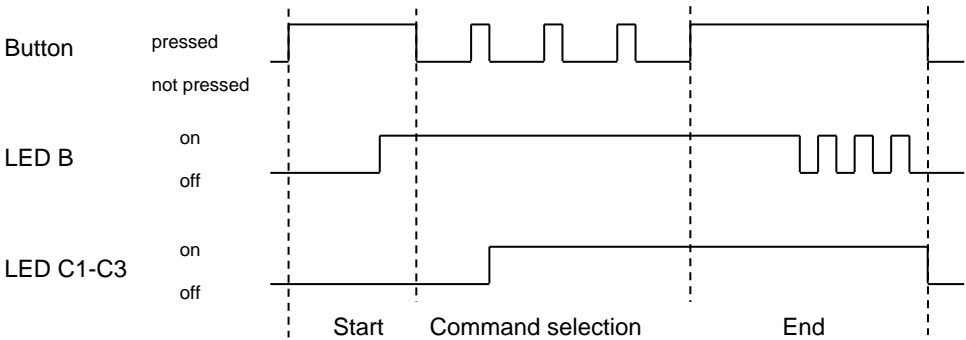

9.1 Explanation of the individual sequences

9.1.1 Start Sequence

The button must be pushed until LED B lights (approximately 3 seconds). If the button is pushed too long (longer than approximately 10 seconds), an Error sequence is initiated (see "Error sequence"). The same applies when the button is released too soon (before LED B lights) or it is pushed immediately after being released (time between 2 button presses shorter than 200 ms).

9.1.2 Command Selection Sequence

After the Start sequence, the desired command is selected. This selection is made with button presses in the following time intervals: Minimum press duration is 200 ms, maximum is approximately 3 seconds; the minimum pause between individual button presses is 200 ms, the maximum is 10 seconds. After each correct button press (incl. The minimum pause of approx. 200 ms), the selected command is shown with LEDs C1, C2 and C3. If an invalid command is selected (see "valid commands"), the Error sequence is initiated; as with not correctly observing the time intervals. LED B lights continuously during this sequence.

9.1.3 End Sequence

This sequence is used to confirm the selected command. Here, the button is pressed until LED starts to blink (approx. 3 seconds, blinks in a slow interval). The number of light pulses in LED B depends on the previously selected command (see "valid commands").

After the LED turns off, the button must be released. After the minimum pause of approximately 200 ms, in which the button must not be pressed, the service mode is started, and the command is executed. If the button pressed for longer than approximately 3 seconds, the selected command is not accepted and the Error sequence is displayed. The same applies when the button is released too soon or the minimum pause of 200 ms is not observed. After executing the command, the corresponding mode is initiated depending on the command (see "Valid Commands").

If executing the command leads to an error (e.g. because SET_VERIFIED should be executed although no valid configuration data is available in the Safety CPU), the Error sequence is initiated.

9.1.4 Error Sequence

If an invalid button press occurs, as in the sequences described above, the Error sequence is initiated. LED B indicates this sequence with fast blinking, which lasts for at least 3 seconds.

If the button is still pressed after 3 seconds, LED B will continue to blink until the button is released and a minimum pause of approximately 200 ms has elapsed. The Start sequence cannot be reinitiated until LED B stops blinking.

After ending the Error sequence, the mode is changed as described in "Overview of Module Statures". If turned on, LEDs C1, C2 and C3 are turned off after ending the Error sequence.

9.2 Overview of Commands

The number of button presses corresponds to the number of light pulses in LED B during the End sequence.

Commands	Number of button presses	LED C1	LED C2	LED C3
QUIT_ERROR	1	X		
CLR_CFG	2	X	X	
SET_VERIFIED	3	X	X	X

9.3 Overview of Module Statuses and Commands

The following tables show a sample of the statuses in which the system can be found, the commands that can be active during the respective status and their functions (see the Safety System handbook for the module statuses).

System status	Command		
	QUIT_ERROR	CLR_CFG	SET_VERIFIED
Check-Configuration		X	
Time-restricted operational mode		X	X
Operational Mode		X	
Service Mode		X	
Error		X	

Executed command	Command function	Status after command execution
QUIT_ERROR	A possible error is cancelled in the Safety CPU and all Safety CPU modules required by the Safety CPU and the error mode is then ended.	SW-RESET ¹⁾
CLR_CFG	The configuration in the Safety CPU is deleted. After executing the instruction, the Safety CPU changes to the service mode.	Service Mode
SET_VERIFIED	The configuration status is set to "verified".	Operational Mode
<p>¹⁾ A SW-RESET is performed. If the error still exists, the Safety CPU remains in the error mode. Otherwise, the Safety CPU starts correctly.</p> <p>General note: If a command was entered incorrectly, the Safety CPU initiates the error sequence (see above). After ending the Error sequence, the command can be reentered.</p>		

9.4 Handling the microSD Card (mSD)

An mSD card can only be written on with the Safety Designer. A detailed description can be found in the Safety System handbook (Link: https://www.sigmatek-automation.com/fileadmin/user_upload/downloads/Safety-Systemhandbuch.pdf).

A Safety project, which was programmed with the SafetyDesigner, can be stored on an mSD card. The stored Safety project can then be loaded into an additional SCP Safety CPU, providing that the module's Flash memory is empty (cleared).

If the configuration on the mSD card is different from that on the Safety CPU Flash, the system switches to the error status (error message 87). The mSD card cannot be inserted into the Safety CPU during normal operation (Operational or temporary operational mode). If the mSD card is inserted during normal operation, the Safety CPU switches to the error status (error message 88). However, an mSD card can be removed during normal operation.

9.5 Configuring a Safety CPU with the mSD Card

The configuration is loaded from an mSD card as follows:

- **Delete the configuration of the Safety CPU to be programmed**

To load the configuration from the mSD card, the configuration in the Safety CPU must first be deleted. This can be done with either the SAFETYDesigner or with help from the CLR_CFG command using validation button on the Safety CPU. Once the configuration in the Safety CPU is deleted, the Safety CPU can no longer return to the operational or temporary operational mode. The Safety CPU remains in the service mode.

- **Insert the mSD card and deactivate the system**

In the next step, an mSD card with the valid configuration must be inserted in the Safety CPU and the system shut down.

- **Restart the system with the mSD card**

When the system is restarted, the configuration is loaded from the mSD card into the Flash of the Safety CPU. This is only possible if a valid configuration is stored on the mSD card. If the mSD card has an incorrect format (error message 86) or the Safety CPU's Flash has not been cleared (error message 87), the Safety CPU goes into the error status. If the configuration does not match the available real modules, the distribution process of the configuration triggers an error (error message 9) and the Safety CPU also goes into safe mode.

- If an error occurs during the restart, see the following chapter "Restart Error".

INFORMATION



A microSD card with a memory capacity of 1 Gigabyte is available from SIGMATEK under the article number 12-630-101.

Only microSD cards that support version 2.0 or higher of the "SDA Physical Layer Specification" (SDA=SD Card Association) can be used.

It is recommended that only microSD cards provided by SIGMATEK be used.

The number of read and write actions have a significant influence on the lifespan of the storage media.

10 Response to Errors

In the event of an error, please consult the chapter "LED Displays", as important information on the runtime status of the system can be derived from the status an error display. Since errors in general are of a complex nature, do not perform a diagnosis based on the LEDs alone (consult the corresponding chapter in the Safety System Handbook as well). For an exact error analysis, the SafetyDesigner must be used.

10.1 Restart Errors

The following diagram shows the response of the Safety CPU module during restart.

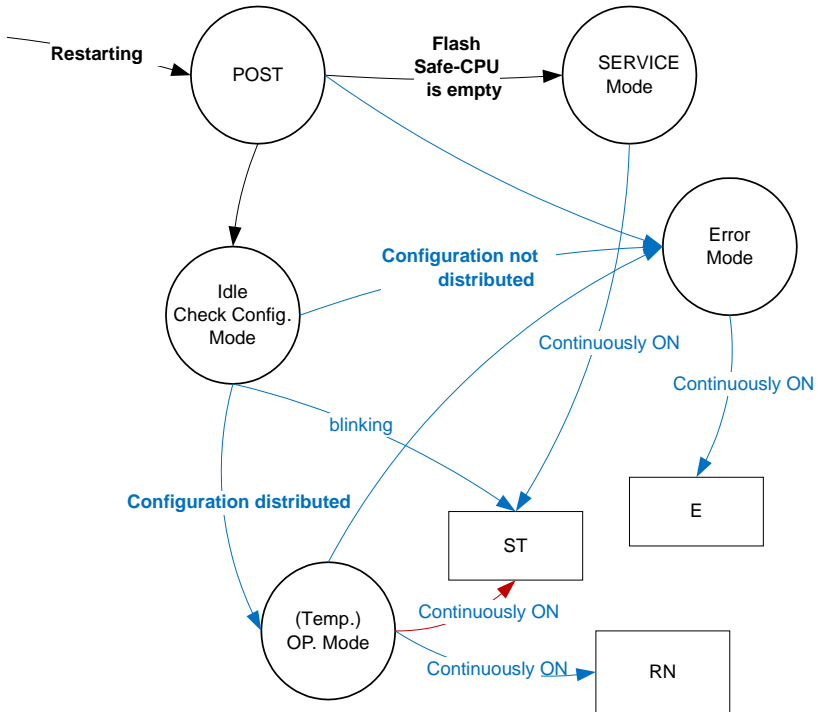

- a) During restart, the Safety CPU first runs the **POST** (Power On Self Test). In the POST, whether the Safety CPU is configured or not is determined. If the Flash memory in the Safety CPU is empty, it changes to the service mode and switches the status LED (ST) to continuously on.
- b) If the Flash memory of the Safety CPU contains a configuration, it goes into the idle / Check Configuration Mode. Thereby, an attempt is made to distribute the configuration; the ST-LED blinks during this process.
- c) If the configuration is successfully distributed, the Safety CPU either goes into the Operational mode or the Temporary Operational mode depending on whether or not the configuration has already been validated. If the System was already validated, the ST-LED turns off and the RN-LED lights. If the system has not been validated, both LEDs light simultaneously.
- d) If for whatever reason the distribution of the configuration is still not successful, the Safety CPU switches to the Error mode and the E-LED lights
- e) When the Safety CPU remains in the idle / Check Configuration Mode for a long period of time (ST-LED blinking) without switching to the Error mode, it is an indication that the bus communication is malfunctioning. In this case, the PLC will remain in the error status and must be restarted.
- f) A change to the error status can also occur from the **POST** and **(Temp.) OP mode** if other (internal) errors are detected or errors in remote modules occur. The analysis of these errors, however, requires the use of the SAFETYDesigner.

10.2 Configuration Distribution Error

If the Safety CPU fails to distribute the configuration, the cause can be traced to one or more of the following errors.

- The configuration and the physical topology do not match
- One or more modules are missing
- More than one module was exchanged
- Communication error with a remote module
- The module to be configured is in error status

10.3 Troubleshooting

- Check all modules in the system for completeness and type conformity
- Check that all modules are error-free
- Check all connector cables
- Cancel the error with the QUIT_ERROR command

If the Safety CPU remains in the error status after the **QUIT_ERROR** command has been executed, it must be retested using the SAFETYDesigner.

10.4 Troubleshooting with the SAFETYDesigner

Connect the SAFETYDesigner
Debug the system using the SAFETYDesigner.

10.5 Correcting a Wiring Error



INFORMATION

When a wiring error is determined, a controlled deactivation of the system is required, which must then be turned off.

Wiring and mounting can only be performed when no power is applied.

11 Wiring Guidelines

The input filters, which suppress noise signals, allow operation in harsh environmental conditions. A careful wiring method is also recommended to ensure error-free function.

The following installation guidelines should be observed:

- Avoid parallel connections between input lines and load-bearing circuits.
- Protective circuits for all relays (RC networks or free-wheeling diodes)
- Correct wiring to ground

INFORMATION



Connect the ground bus to the control cabinet!

Wiring and installation must be performed while no voltage is applied!

The S-DIAS module cannot be connected/disconnected while voltage is applied!

11.1 Shielding

The Safety bus wiring must be shielded.

The low-ohm shielding must be either connected either at the entry to the control cabinet or directly before the SCP 211 over a large surface (cable grommets, grounding clamps)!

Noise signals can therefore be prohibited from reaching the electronics and affecting the function.

To avoid compensating currents from the PE, which flow over the shielding the conductors, it is recommended that the system components have low Ohm and low impedance connections to one another.

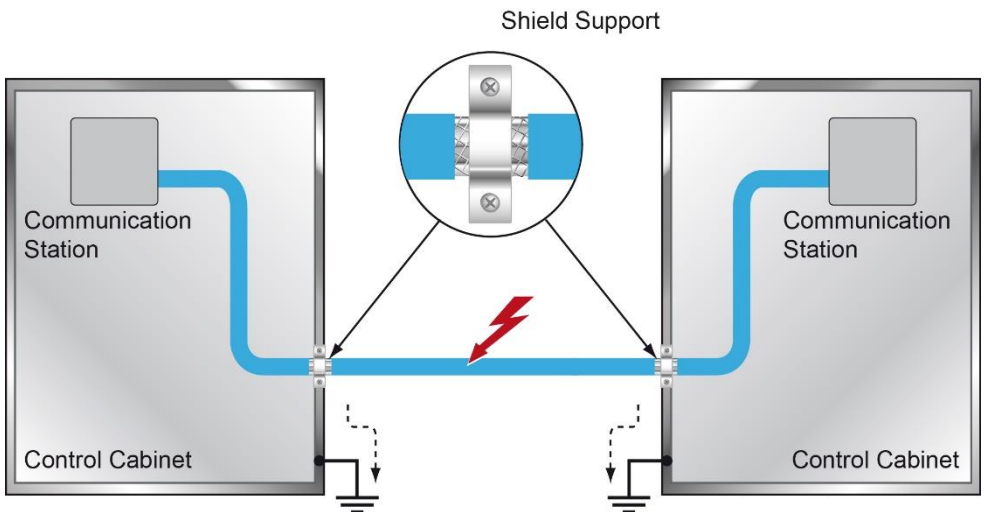

11.2 ESD Protection

CAUTION



The operator must ensure that no interference from ESD affects the product.

12 Assembly/Installation

12.1 Check Contents of Delivery

Ensure that the contents of the delivery are complete and intact. See chapter Contents of Delivery.

INFORMATION



On receipt and before initial use, check the device for damage. If the device is damaged, contact our customer service and do not install the device in your system.

Damaged components can disrupt or damage the system.

12.2 Mounting

The S-DIAS modules are designed for installation into the control cabinet. To mount the modules, a DIN-rail is required. The DIN rail must establish a conductive connection with the back wall of the control cabinet. The individual S-DIAS modules are mounted on the DIN rail as a block and secured with latches. The modules must be mounted horizontally (module label up) with sufficient clearance between the ventilation slots of the S-DIAS module blocks and nearby components and/or the control cabinet wall. This is necessary for optimal cooling and air circulation to ensure proper function up to the maximum operating temperature.

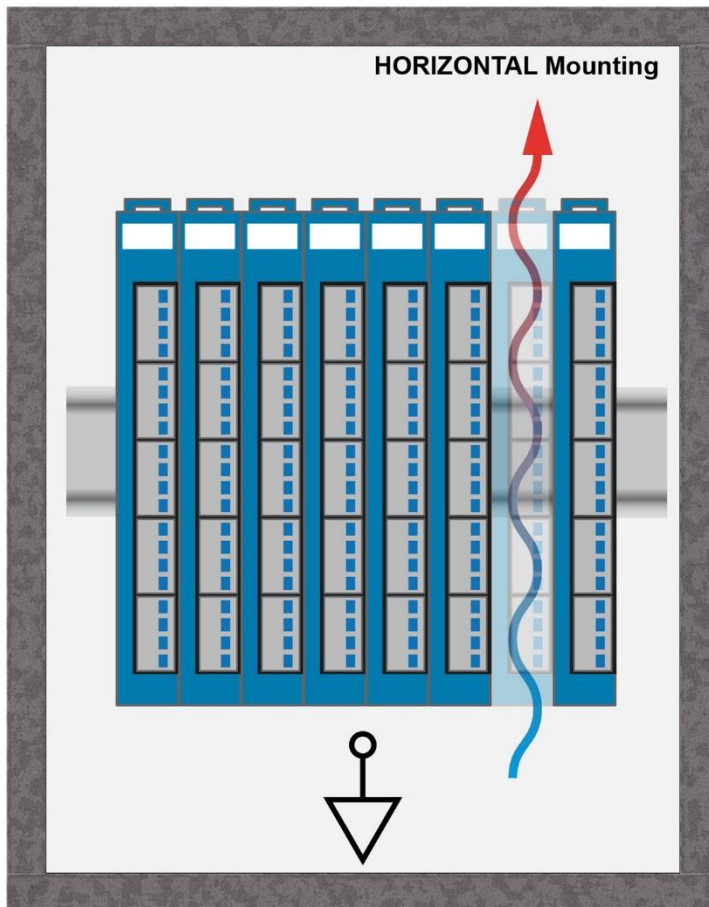

Recommended minimum distances between the S-DIAS modules and the surrounding components or control cabinet wall:

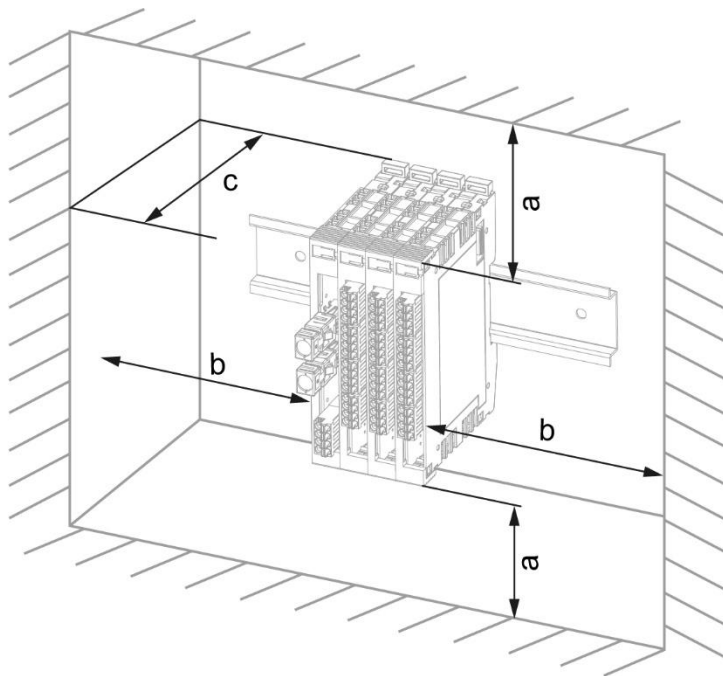

a	b	c
30 mm (1.18")	30 mm (1.18")	100 mm (3.94")

a, b, c ... distances in mm (inches)

13 Supported Cycle Times

The SCP 211 can be accessed via the S-DIAS bus with different bus cycle times.

13.1 Cycle Times below 1 ms (in μs)

50	100	125	200	250	500
x	x	x	x	x	x

x= supported

13.2 Cycle Times equal to or higher than 1 ms (in ms)

1	2	3	4	5	6	7	8	9	10	11	12	13	14	15	16
x	x	x	x	x	x	x	x	x	x	x	x	x	x	x	x

x= supported

17	18	19	20	21	22	23	24	25	26	27	28	29	30	31	32
x	x	x	x	x	x	x	x	x	x	x	x	x	x	x	x

x= supported

14 Transport/Storage

INFORMATION



This device contains sensitive electronics. During transport and storage, high mechanical stress must therefore be avoided.

For storage and transport, the same values for humidity and vibration as for operation must be maintained!

Temperature and humidity fluctuations may occur during transport. Ensure that no moisture condenses in or on the device, by allowing the device to acclimate to the room temperature while turned off.

When sent, the device should be transported in the original packaging if possible. Otherwise, packaging should be selected that sufficiently protects the product from external mechanical influences. Such as cardboard filled with air cushioning.

15 Storage

INFORMATION



When not in use, store the device according to the storage conditions. See chapter 14 Transport/Storage.

During storage, ensure that all protective covers (if available) are placed correctly, so that no contamination, foreign bodies or fluids enter the device.

16 Maintenance

INFORMATION



During maintenance as well as servicing, observe the safety instructions from chapter 2 Basic Safety Directives.

16.1 Service

This product was constructed for low-maintenance operation.

16.2 Repair

INFORMATION



In the event of a defect/repair, send the device with a detailed error description to the address listed at the beginning of this document.

For transport conditions, see chapter 14 Transport/Storage.

17 Disposal

INFORMATION



Should you need to dispose of the device, the national regulations for disposal must be followed.

The device appliance must not be disposed of as household waste.



Documentation Changes

Change date	Affected pages	Chapter	Note
05.12.2023	14	3 IT Security	Chapter added
	23	6.4 Miscellaneous	Mission time added
	23	6.4 Environmental Conditions	Noise emissions added
	44	13 Supported Cycle Times	Description added
01.02.2024	16	4.3.2 EU Conformity Declaration	Note on download adjusted
	17	4.4 Safety-Relevant Parameters	The safety indicators (PFH, MTTFD) were adjusted slightly with the recertification.
21.02.2024			Wording of standards corrected

