

ST 151(-X)

S-DIAS Stepper Motor Output Stage

INSTRUCTION MANUAL

Article number: 20-014-151-D

Date of creation: 23.10.2017

Version date: 21.01.2026

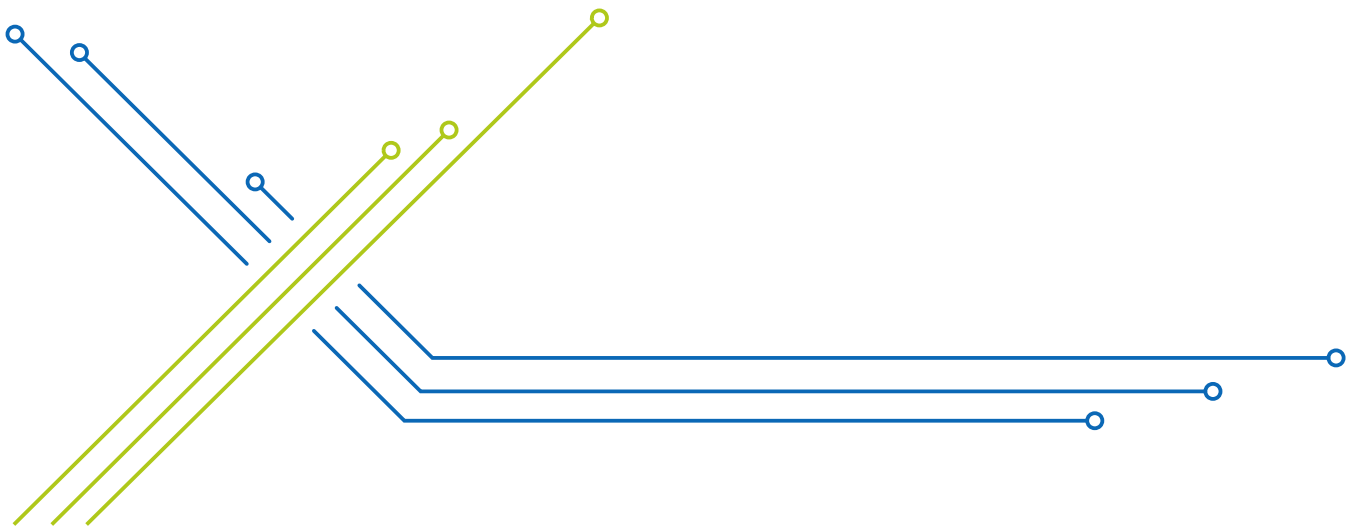

Publisher:

SIGMATEK GmbH & Co KG
A-5112 Lamprechtshausen
Tel.: +43/6274/4321
Fax: +43/6274/4321-18

Email: office@sigmatek.at
www.sigmatek-automation.com

All rights reserved. No part of this work may be reproduced, edited using an electronic system, duplicated or distributed in any form (print, photocopy, microfilm or in any other process) without express permission.

We reserve the right to make changes in the content without notice. SIGMATEK GmbH & Co KG is not responsible for technical or printing errors in this handbook and assumes no responsibility for damages that occur through its use.

S-DIAS Stepper Motor Output Stage

ST 151(-X)

- 1 stepper motor output stage 50 V/5 A**
- 1 brake chopper**
- 1 incremental encoder input RS422/TTL switchable**
- 2 enable inputs +24 V/3.2 mA/0.5 ms with STO function**
- 2 latch/digital inputs+24 V/3.7 mA/10 μ s**

The S-DIAS stepper motor output stage allows the connection of 2-phase stepper motors with a phase current up to 5 A. In the standard step frequency mode, the operating modes half step, full step and micro step (up to 64x) is supported.

The integrated brake chopper provides the connection for an external regen resistor, with which excess energy generated by the braking process of the motor can be dissipated.

The incremental encoder input, which supports RS422 as well as TTL encoders, is provided for position feedback.

With both enable inputs, the safety function STO is implemented.

The 2 latch/digital inputs are provided for the reference motion and monitoring the end positions.

This instruction manual also applies to the product ST 151(-X) (main board and S-DIAS connectors coated in Purocoat (Certonal)), which is no longer explicitly mentioned in the following.



Table of Contents

1 Introduction	5
1.1 Target Group/Purpose of this Operating Manual	5
1.2 Important Reference Documentation	5
1.3 Contents of Delivery	5
2 Basic Safety Directives	6
2.1 Symbols Used	6
2.2 Disclaimer	7
2.3 General Safety Directives	7
2.4 Designated Use	9
2.5 Software/Training	10
3 IT Security	11
4 Standards and Directives	12
4.1 Residual Risks	12
4.2 Safety of the Machine or Equipment	12
4.3 Directives	12
4.3.1 Functional Safety Standards	13
4.3.2 EU Declaration of Conformity	13
4.4 Safety-Relevant Parameters	13
4.5 Compatibility	13
5 Type Plate	14
6 Technical Data	15
6.1 Stepper Motor Output Specification	15
6.2 Brake Chopper Specifications	16
6.3 Incremental Encoder Input Specifications	17
6.4 Latch/Digital Inputs Specifications	17
6.5 Enable Inputs for STO Specifications	17
6.6 Electrical Requirements	18
6.7 Miscellaneous	20
6.8 Environmental Conditions	20
7 Mechanical Dimensions	21
8 Connector Layout	22

8.1 Status LEDs	23
8.2 Applicable Connectors	24
8.3 Label Field	25
9 Wiring	26
9.1 Wiring Example	26
9.2 Note	27
10 Description of Functions	28
10.1 Stepper Motor Output Stage Operating Modes	28
10.1.1 Full Step Mode	28
10.1.2 Half Step Mode	28
10.1.3 Micro Step Mode	29
10.2 Stepper Motor Current Regulator	29
10.2.1 Signal Process "Count UP"	30
10.2.2 Signal Process "Count DOWN"	31
10.2.3 Signal Process "Reference impulse (Zero Position)"	31
10.2.4 Latch Function	31
11 Additional Safety Information	32
11.1 STO	35
11.2 Function	35
11.3 Function Test	36
12 Wiring Examples	37
12.1 Performance Level e, Category 4 or SIL 3 - Safety PLC	37
12.2 Performance Level e, Category 3 or SIL 3 - Safety PLC	39
12.3 Performance Level e, Category 4 or SIL 3 - Conventional	41
12.4 Performance Level e, Category 2 or SIL 2 - Conventional	43
13 Assembly/Installation	45
13.1 Check Contents of Delivery	45
13.2 Mounting	45
14 Transport/Storage	47
15 Storage	48
16 Maintenance	49
16.1 Service	49

16.2 Repair 49

17 Disposal 50

1 Introduction

1.1 Target Group/Purpose of this Operating Manual

This operating manual contains all information required for the operation of the product.

This operating manual is intended for:

- Project planners
- Technicians
- Commissioning engineers
- Machine operators
- Maintenance/test technicians

General knowledge of automation technology is required.

Further help and training information, as well as the appropriate accessories can be found on our website www.sigmatek-automation.com.

Our support team is happily available to answer your questions.
Please see our website for our hotline number and business hours.

1.2 Important Reference Documentation

- Safety System Handbook

This and additional documents can be downloaded from our website or obtained through support.

1.3 Contents of Delivery

1x ST 151(-X)

2 Basic Safety Directives

2.1 Symbols Used

The following symbols are used in the operator documentation for warning and danger messages, as well as informational notes.



DANGER

Danger indicates that death or serious injury **will occur**, if the specified measures are not taken.

→ To avoid death or serious injuries, observe all guidelines.

Danger indique une situation dangereuse qui, faute de prendre les mesures adéquates, **entraînera** des blessures graves, voire mortelles.

→ Respectez toutes les consignes pour éviter des blessures graves, voire mortelles.



WARNING

Warning indicates that death or serious injury **can** occur, if the specified measures are not taken.

→ To avoid death or serious injuries, observe all guidelines.

Avertissement d'une situation dangereuse qui, faute de prendre les mesures adéquates, **entraînera** des blessures graves, voire mortelles.

→ Respectez toutes les consignes pour éviter des blessures graves, voire mortelles.



CAUTION

Caution indicates that moderate to slight injury **can** occur, if the specified measures are not taken.

→ To avoid moderate to slight injuries, observe all guidelines.

Attention indique une situation dangereuse qui, faute de prendre les mesures adéquates, **peut** entraîner des blessures assez graves ou légères.

→ Respectez toutes les consignes pour éviter des blessures graves, voire mortelles.



DANGER

Electrical voltage

Tension électrique



WARNING

Hot Surfaces

Surfaces chaudes

CAUTION

Danger for ESD-sensitive components.

Les signes de danger pour les composants sensibles aux décharges électrostatiques.

INFORMATION**INFORMATION**

- Provides important information on the product, handling or relevant sections of the documentation, which require particular attention.

2.2 Disclaimer

The contents of this operating manual were prepared with the greatest care. However, deviations cannot be ruled out. This operating manual is regularly checked and required corrections are included in the subsequent versions. The machine manufacturer is responsible for the proper assembly, as well as device configuration. The machine operator is responsible for safe handling, as well as proper operation.

The current operating manual can be found on our website. If necessary, contact our support.

Subject to technical changes, which improve the performance of the devices. The following operating manual is purely a product description. It does not guarantee properties under the warranty.

Please thoroughly read the corresponding documents and this operating manual before handling a product.

SIGMATEK GmbH & Co KG is not liable for damages caused through, non-compliance with these instructions or applicable regulations.

2.3 General Safety Directives

The Safety Directives in the other sections of this operating manual must be observed. These instructions are visually emphasized by symbols.

According to EU Directives, the operating manual is a component of a product. This operating manual must therefore be accessible in the vicinity of the machine since it contains important instructions. This operating manual should be included in the sale, rental or transfer of the product, or its online availability indicated.

Regarding the requirements for Safety and health connected to the use of machines, the manufacturer must perform a risk assessment in accordance with machine directives 2006/42/EG before introducing a machine to the market.

INFORMATION

Operate the unit with devices and accessories approved by SIGMATEK only.

CAUTION

Handle the device with care and do not drop or let fall.
Prevent foreign bodies and fluids from entering the device.
The device must not be opened!

Manipulez l'appareil avec précaution et ne le laissez pas tomber.
Empêchez les corps étrangers et les liquides de pénétrer dans l'appareil.
L'appareil ne doit pas être ouvert!

If the device does not function as intended or has damage that could pose a danger, it must be replaced!

En cas de fonctionnement non conforme ou de dommages pouvant entraîner des risques, l'appareil doit être remplacé !

For your own safety and that of others, compliance with the environmental conditions is essential.

Pour votre propre sécurité et celle des autres, le respect des conditions environnementales est essentiel.

2.4 Designated Use

The Safety functions implemented in the product are designed for use with safety applications in a PLC control and meet the required conditions for safe operation.

CAUTION



The instructions contained in this operating manual must be followed. For error-free operation, proper transport and storage are essential. Installation, mounting, programming, initial start-up, operation, maintenance and decommissioning can only be performed by qualified personnel. Qualified personnel in this context are people, who have completed training or have trained under supervision of qualified personnel and have been authorized to operate and maintain safety-related equipment, systems and facilities in compliance with the strict directives and standards of safety technology (Functional Safety).

Les instructions contenues dans ce manuel technique doivent être suivies. Pour un fonctionnement sans erreur, le transport et le stockage appropriés sont essentiels.

L'installation, le montage, la programmation, la mise en service initiale, l'exploitation, la maintenance et la mise hors service ne peuvent être effectués que par une personne qualifiée.

Dans ce contexte, on entend par personnel qualifié les personnes qui ont suivi une formation ou qui ont été formées sous la supervision d'un personnel qualifié et qui ont été autorisées à utiliser et à entretenir l'équipement, les systèmes et les installations de sécurité conformément aux directives et aux normes strictes de la technique de sécurité (Sécurité fonctionnelle).

For your own safety and that of others, the product should be used for their designated purpose only.

Correct EMC installation is also included under designated use.

Pour votre propre sécurité et celle des autres, le produit ne doivent être utilisés qu'à des fins prévues.

Une installation CEM correcte est également incluse dans l'utilisation prévue.

Non-designated use consists of:

- any changes made to the module or the use of damaged modules.
- use of the module inconsistent with the technical margins described in this operating manual or the specifications defined in the technical data.

L'utilisation non désignée consiste en:

- toute modification apportée au module ou l'utilisation des modules endommagés.
- utilisation du module non conforme aux marges techniques décrites dans ce manuel ou aux spécifications définies dans les données techniques.

2.5 Software/Training

The application is created with the software LASAL CLASS 2 and LASAL SCREEN Editor, the Safety application is created using the SAFETYDesigner. Basic information on Safety (Functional Safety) can be found in the Safety System Handbook.

Training for the LASAL development environment, with which the product can be configured, is provided. Information on our training schedule can be found on our website.

3 IT Security

S-DIAS safety modules were developed for integration into a network protected against unauthorized access.

For example, the following dangers can affect the network:

- Unauthorized access
- Data manipulation
- and many other IT security violations

It is the responsibility of the integrator or operator to carry out a risk analysis of the connections between S-DIAS modules and the integration into the overall infrastructure. The following measures, for example, may result from this (if necessary):

- Separation of IT/OT networks (VLANs or physical)
- Firewalls
- Password-protected user accounts
- Data encryption
- and much more

With regard to the functional safety objective, in this case the STO safety function, no direct effects on the function or its integrity are possible, since the function cannot be influenced via communication-based interfaces.

The availability of the overall system (as with all safety functions) can be compromised by external attacks, hence the above measures are necessary.

4 Standards and Directives

4.1 Residual Risks



CAUTION

The following residual risks for the product must be included in the system integrator's risk assessment:

- Release of non-environmentally safe substances, emissions and unusual temperatures
- Hazardous contact voltages
- Effects of operational electrical, magnetic and electromagnetic fields
- Possible effects of information technology devices

Les risques résiduels suivants pour le produit doivent être inclus dans l'évaluation des risques de l'intégrateur de système :

- Libération de substances non respectueuses de l'environnement, émissions et températures inhabituelles
- Tensions de contact dangereuses
- Effets des champs électriques, magnétiques et électromagnétiques opérationnels
- Effets possibles des dispositifs de technologie de l'information

4.2 Safety of the Machine or Equipment

Observe all on-site rules and regulations for accident prevention and occupational safety.

4.3 Directives

The product was constructed in compliance with the following European Union directives and tested for conformity.

4.3.1 Functional Safety Standards

EN IEC 62061	Safety of machinery - Functional safety of safety-related control systems
EN ISO 13849-1	Safety of machinery - Safety-related parts of control systems - Part 1: General principles for design
EN ISO 13849-2	Safety of machinery - Safety-related parts of control systems - Part 2: Validation
EN IEC 61508-1	Functional safety - Part 1: General requirements
EN IEC 61508-2	Functional safety - Part 2: Requirements for electrical / electronic / programmable electronic safety-related systems
EN IEC 61508-3	Functional safety - Part 3: Software requirements

The issue status of the applied standards can be found in the EU declaration of conformity.

4.3.2 EU Declaration of Conformity



EU Declaration of Conformity

The product ST 151(-X) conforms to the following European directives:

- 2006/42/EG Machine Directive
- 2014/30/EU Electromagnetic Compatibility (EMC Directive)
- 2011/65/EU "Restricted use of certain hazardous substances in electrical and electronic equipment" (RoHS Directive)

The EU Conformity Declarations are provided on the SIGMATEK website. They can be found in the download area of the respective product.

4.4 Safety-Relevant Parameters

Safety parameters for two channel operation of the ST 151(-X)		
	Safety Parameters	Safety Level
EN IEC 62061	PFH = 7.00E-10 (1/h)	SIL 3
	SFF = 99 %	
EN ISO 13849-1	MTTF _D = 2820 years	PL e / Cat. 4
	DC = 99 %	

4.5 Compatibility

INFORMATION





Compatibility

For compatibility of the S-DIAS Safety modules, see section "Compatibility of S-DIAS Safety Modules" in the system handbook.

5 Type Plate

The type plate provides information about the product's features. The type plate shown here is only an example.

Approbations		Standards
QR-Code  BJ: XXXX/XX S/N XXXXXXXX	Short Name Specifications FS: XXX.XX.XX FW: XXX LD: XX.X HW: X.XX	Electrical Ratings  Sigmatekstraße 1 A-5112 Lamprechtshausen www.sigmatek-automation.com
Article Number		Product Name

- HW: Hardware version
- FS: Safety version number
- FW: Firmware version
- LD: Logic device version
- QR-Code: Serial number

6 Technical Data

6.1 Stepper Motor Output Specification

Number of phases	2
Output voltage	dependent on the supply (18-55 V)
Current controller frequency	maximum 32 kHz
Output current	maximum 5 A _{RMS}
Output current over the environmental temperature	maximum 5 A continuous current at 45 °C
	maximum 3 A continuous current at 55 °C
DC-link capacitance	10 µF
Operating modes	step frequency mode
Step resolution	full step, half step ¹⁾
	4-/8-/16-/32-/64x micro step
Voltage measurement	+15-70 V
	with an under voltage < 15 V or over voltage > 70 V, the motor output is shut down through the hardware.
Temperature measurement	0-125 °C
	with temperature warning at 103 °C
	with overtemperature cut-off at 108 °C

INFORMATION



Note on frequency resonance

Operating a stepper motor in the stepper frequency default mode can lead to resonance in certain frequency ranges. This is indicated by loss or torque reduction => the stepper motor loses steps. This phenomenon is a result of the stepper motor construction and depends on the load. The problem can be minimized or avoided by half or micro step operation.

¹⁾ In the operation modes half and micro step, the current amplitude is raised by a factor of $\sqrt{2}$. With this current increase, nearly 95 % of the full step torque and in micro step mode, 100 % of full step torque is achieved. In half step mode, the current increase must be activated through the software.

6.2 Brake Chopper Specifications

Number	1
Output	GND switching
Maximum current	6 A ¹⁾
Short-circuit protection	yes
Regen resistor	external power resistor
Article number	20-014-061-Z1
Regen resistor switching threshold on/off	60 V/55 V

WARNING



Hot surface warning!

A burn hazard exists with physical contact!

During operation, the surface of the brake resistor can become very hot and remain hot sometime after operation.

Avoid physical contact with the surface of the brake resistor, and for a significant time after operation as well.

Avertissement de surface chaude!

Il existe un risque de brûlure par contact physique!

Pendant le fonctionnement, la surface de la résistance de freinage peut devenir très chaude et rester chaude quelque temps après le fonctionnement.

Eviter tout contact physique avec la surface de la résistance de freinage, ainsi que pendant une longue période après le fonctionnement.

¹⁾ Regen braking must be dimensioned according to the application. For most applications, a 15 Ω/100 W resistor is sufficient. If multiple S-DIAS Stepper Motor Output Stage are driven with one intermediate circuit supply, it is possible to equip only one module with regen braking. The recommended regen resistor is available at SIGMATEK under the article number 20-014-061-Z1.

6.3 Incremental Encoder Input Specifications

Number	1
Input signals	Incremental encoder signals RS422 (A, /A, B, /B, R, /R)
	RS422 level (120 Ω termination, integrated in module)
	Incremental encoder signal TTL (A, B, R)
	TTL level (1200 Ω pull-up, integrated in module)
Input frequency	maximum 125 kHz
Counter frequency	maximum 500 kHz
Signal analysis	4x
Counter resolution	16 bits
Encoder power supply	+5 V/0.2 A short-circuit proof

6.4 Latch/Digital Inputs Specifications

Number	2	
Input voltage	typically +24 V	maximum +30 V
Signal level	low: < +5 V	high: > +15 V
Switch hysteresis	typically +11 V	
Input current	3.7 mA at +24 V	
Input delay	typically 10 μ s	

6.5 Enable Inputs for STO Specifications

Number	2	
Input voltage	+24 V DC	
Input voltage range	minimum +18 V	maximum +30 V
Signal level	low: \leq +5 V	high: \geq +15 V
Switch hysteresis	typically +11 V	
Input current	3 mA at +24 V	
Input delay	typically 0.5 ms	
Safety Level	complies with the requirements of Category 4, Performance Level "e" according to EN ISO 13849-1 and SIL CL 3 according to EN IEC 62061	
Safety function	STO according to EN61800-5-2, section 4.2.2.2	
	The motor is not supplied with energy, which can cause a turn. The stepper motor output stage does not supply energy to the motor, which can generate torque.	

6.6 Electrical Requirements

Supply from S-DIAS bus	+18-55 V DC	
Current consumption of the motor supply	maximum 6 A (load-dependent)	
Supply from S-DIAS bus	+5 V, NEC Class 2	
Current consumption on the S-DIAS bus (+5 V supply)	-	-
Supply from S-DIAS bus	+24 V	
Current consumption on the S-DIAS bus (+24 V supply)	typically 80 mA (incl. +5 V supply of the incremental encoder)	maximum 120 mA (incl. +5 V supply of the incremental encoder)

INFORMATION



Notes on Voltage Ripples in the Motor Supply

The motor supply (X2) must be connected with an intermediate circuit capacitance appropriate for the application (at least 2000 $\mu\text{F}/100\text{ V}$). Attention must be paid to short cables and appropriate cable cross-sections.

(maximum 15 cm between module and capacitor / 1.5 mm²)

To keep the voltage ripple within the allowable range ($< 2\text{ V}_{\text{ss}}$), an electrolyte capacitor of the appropriate value must be connected in parallel to the motor supply terminals. As a reference value for the required capacitance, approximately 2000 μF per Ampere supply current can be assumed. To achieve optimal EMC ratio, it is recommended that the capacitor be mounted near the output stage of the stepper motor and the connection lines be as short as possible.

Stepper Motor Braking

When applying the brake in a stepper motor, a generative process can occur whereby the kinetic energy of the motor is converted into electrical energy. The energy of the motor is thereby fed back into the supply of the stepper motor output stage; this then increases the supply voltage. It should be noted that a regenerative voltage of 65 V at the motor supply connection is not exceeded! The external capacity of the motor supply is may be needed. If the capacitors in the power supply are insufficient, a regen resistor, which converts the excess energy into heat must be connected to the stepper motor output stage. When selecting the power supply, it is important to ensure that it is appropriately feedback-resistant up to the maximum regenerative voltage that occurs.

INFORMATION



Note S-DIAS Supply

If this S-DIAS module is connected to an S-DIAS supply module with several S-DIAS modules, the total current of the modules used must be determined and checked.

The total current of the +24 V supply cannot exceed 1.6 A!

The total current of the +5 V supply cannot exceed 1.6 A!

The specification for the current can be found in the module-specific documentation under "Electrical Requirements".

Incorrectly set parameter or incorrect wiring can lead to destruction of the motor. In particular, motor currents and the I²T settings (A-I2TT, A-I2TERR) must be monitored, which can be parameterized in the DIAS-Drive Editor via the LASAL Class 2 tool.

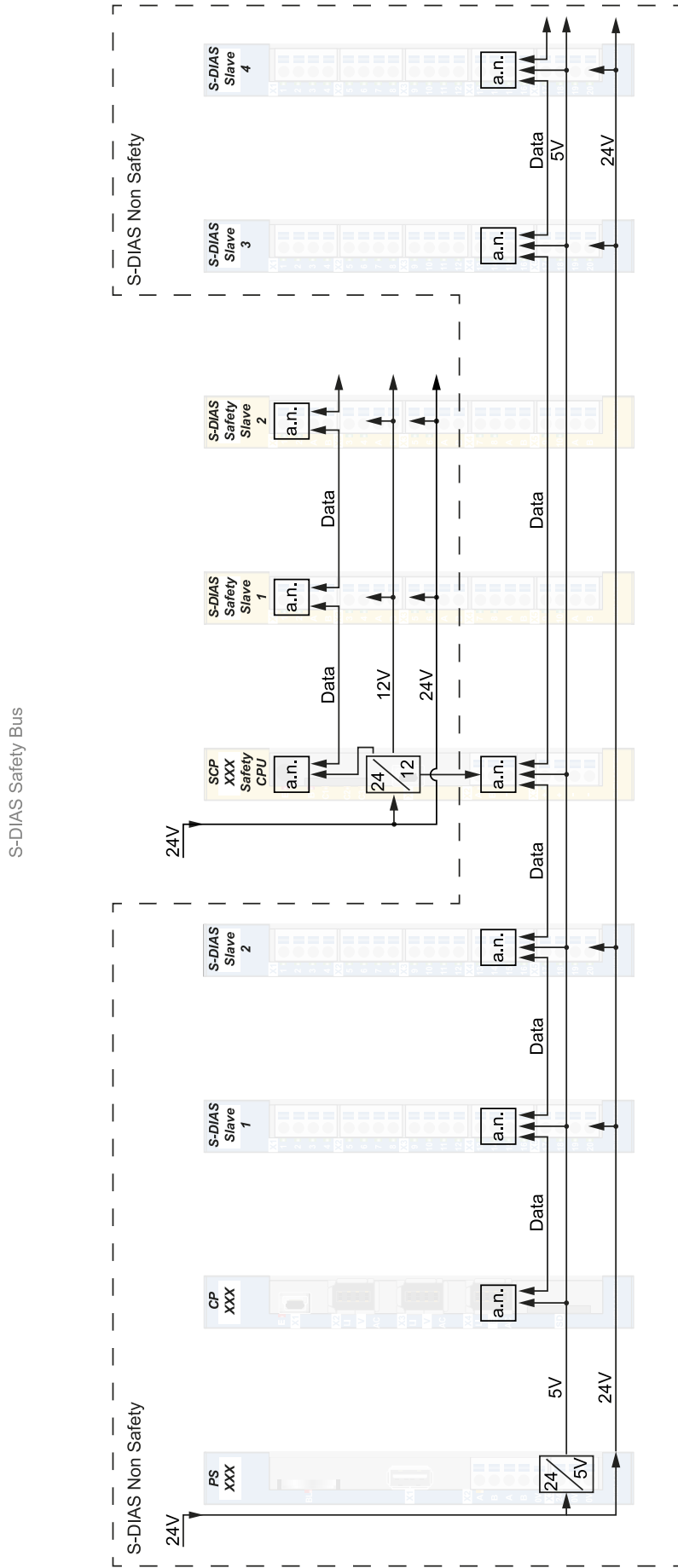

Wiring S-DIAS Safety in S-DIAS System

- each S-DIAS module is an active module (active node)
- Safety CPU is connected to the S-DIAS bus (incl. +5 V supply)
- Safety bus is independent and separated from the S-DIAS bus

a.n. = active node

6.7 Miscellaneous

Article number	20-014-151	
Printed circuit board coating	20-014-151-X (Printed circuit board with protective lacquer)	
Approvals	CE	yes
	UL	cULus (E336350)
	Functional Safety	yes
	UKCA	no
Mission time	20 years	

6.8 Environmental Conditions

Storage temperature	-20 ... +85 °C	
Environmental temperature	0 ... +55 °C ¹⁾	
Humidity	0-95 %, non-condensing	
Installation altitude above sea level	0-2000 m without derating > 2000 m up to a maximum of 5000 m with derating of the maximum environmental temperature by 0.5 °C per 100 m	
Operating conditions	pollution degree 2	
Noise emission	≤ 70 dB	
EMC resistance	EN 61000-6-2 (industrial area) (increased requirements according to EN IEC 62061) EN 61000-6-7 (immunity industry functional safety)	
EMC noise generation	EN 61000-6-4 (industrial area)	
Vibration resistance	EN 60068-2-6	3.5 mm von 5-8.4 Hz 1 g von 8.4-150 Hz
Shock resistance	EN 60068-2-27	15 g (147.15 m/s ²)
Protection type	EN 60529/NEMA 250	IP20/Type1 (not evaluated by UL)

¹⁾ maximal 5 A continuous current at 45 °C, maximum 3 A continuous current at 55 °C

7 Mechanical Dimensions

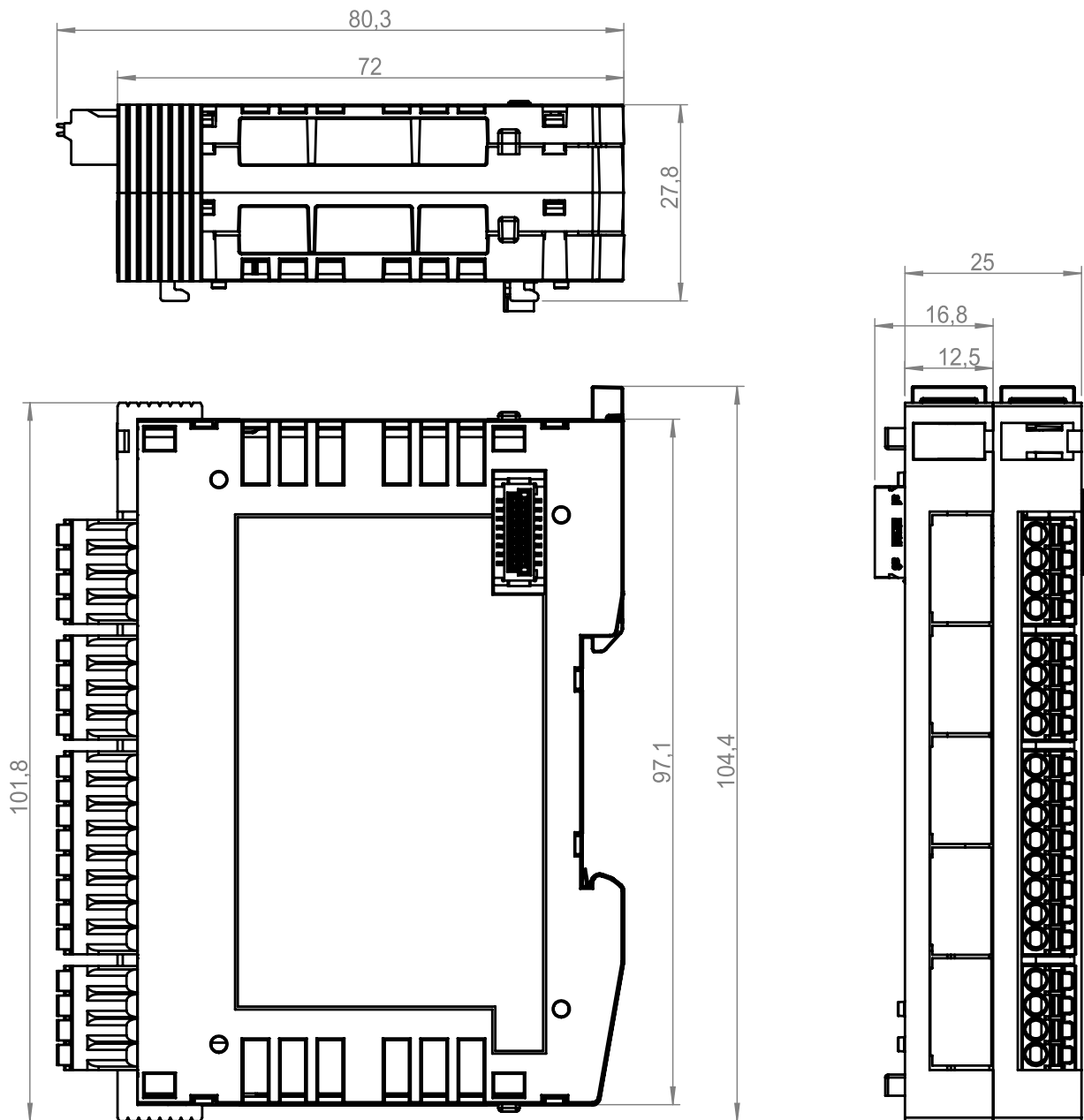

Measurements

25 x 104 x 72 mm (W x H x D)

8 Connector Layout

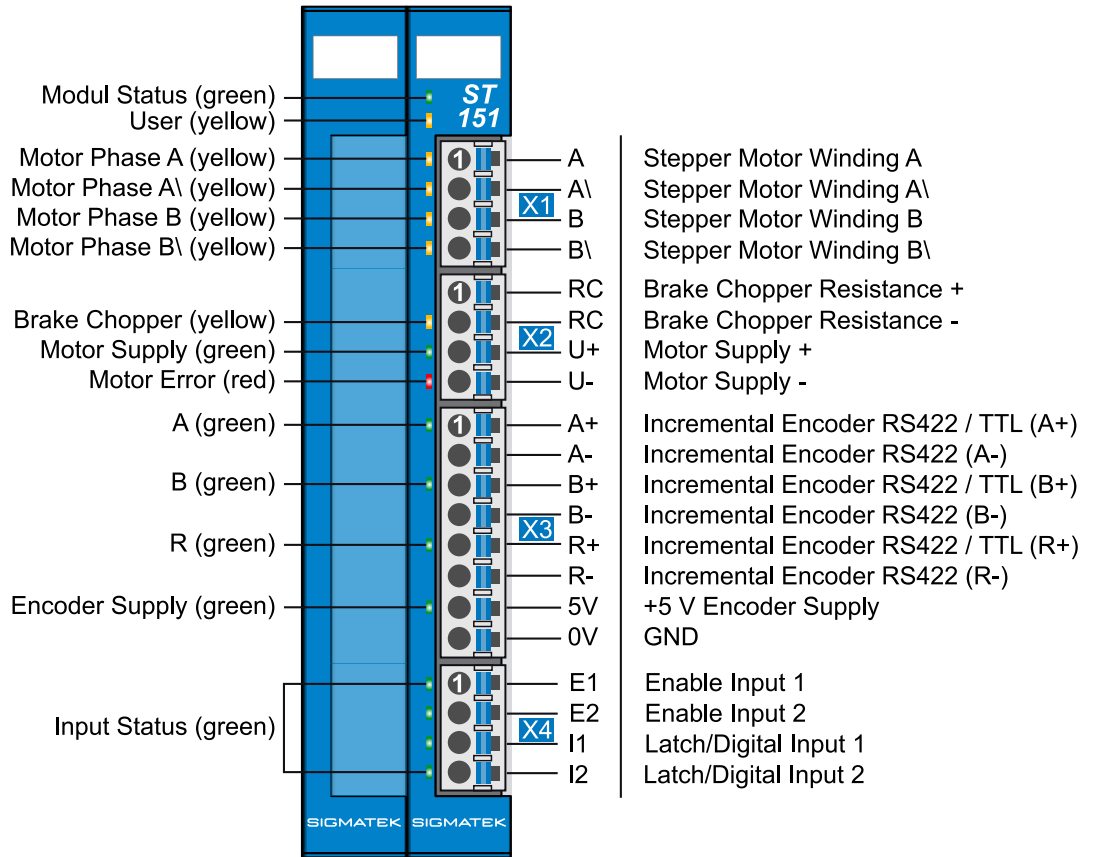

INFORMATION



The motor power connector X2, cannot be inserted or removed during operation!

8.1 Status LEDs

Module status	green	ON	module active
		OFF	no supply available
		BLINKING (5 Hz)	no communication
User	yellow	ON	adjustable by application (e.g. the module LED can be set to blinking through the visualization so that the module is easily found in the control cabinet)
		OFF	
		BLINKING (2 Hz)	
		BLINKING (4 Hz)	
Motor phase A, A\, B, B\	yellow	ON	motor phase active
		OFF	no phase control
Brake chopper	yellow	ON	brake chopper active
		OFF	brake chopper inactive
Motor supply	green	ON	motor supply available, motor active
		OFF	motor supply not available
		BLINKING	motor supply available, motor inactive
Motor error	red	ON	stepper motor output stage error (external enable inputs E1 & E2, inactive/missing or internal module error, STO error)
		OFF	no errors
Encoder signal A, B, R	green	ON	encoder signal HIGH
		OFF	encoder signal LOW
Encoder power supply	yellow	ON	encoder supply OK
		OFF	no encoder supply
Enable input 1,2	green	ON	input ON
		OFF	input OFF
Latch/digital input 1,2	green	ON	input ON
		OFF	input OFF

8.2 Applicable Connectors

X1-X4: Connectors with spring terminals (included in delivery)

The spring terminals are suited for the connection of ultrasonically compacted (ultrasonically welded) stranded wire.

Connection capacity:

Stripping length/sleeve length	10 mm
Mating direction	parallel to conductor axis or to circuit board
Conductor cross section rigid	0.2-1.5 mm ²
Conductor cross section flexible	0.2-1.5 mm ²
Conductor cross section, ultrasonically compacted	0.2-1.5 mm ²
Conductor cross section AWG/kcmil	24-16
Conductor cross section flexible with ferrule without plastic sleeve	0.25-1.5 mm ²
Conductor cross section flexible with ferrule with plastic sleeve	0.25-0.75 mm ² (reason for reducing d2 of the ferrule)

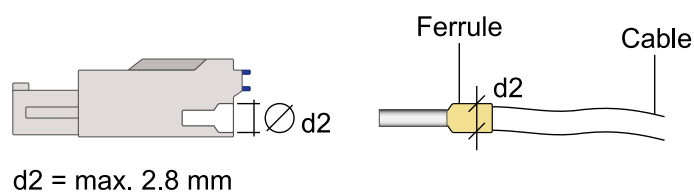

8.3 Label Field

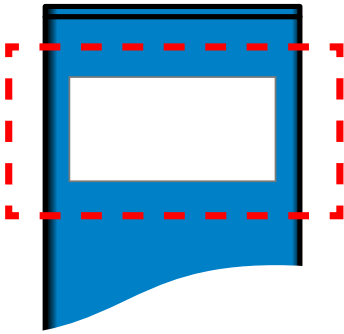

Manufacturer	Weidmüller
Type	MF 10/5 CABUR MC NE WS
Article number Weidmüller	1854510000
Compatible printer	Weidmüller
Type	Printjet Advanced 230V
Article number Weidmüller	1324380000

9 Wiring

9.1 Wiring Example

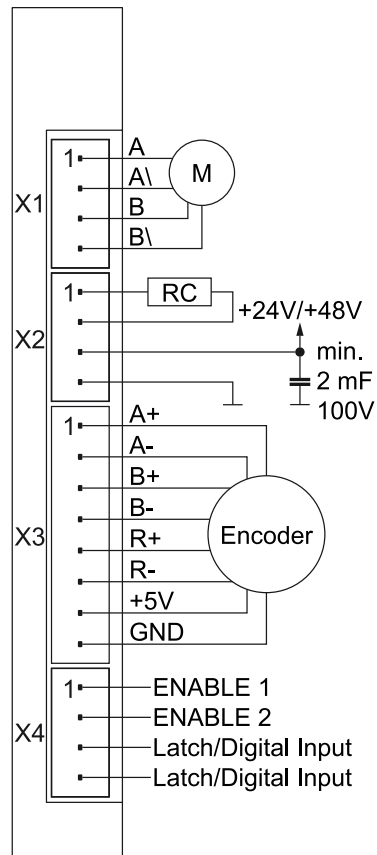

9.2 Note

The following installation guidelines should be observed:

- The DIN rail must have an adequate mass connection.
- The shielding must be connected to a shielding bus.
- To wire the incremental encoder, a shielded cable is required. With an RS422 encoder, the use of shielded, twisted pair cables is recommended. The shield must be placed as close as possible before the module.
- For the motor wiring, a shielded cable is required. The shield must be placed as close as possible to the module.

INFORMATION



The ground bus should be connected to the control cabinet when possible!

Copper cables designed for at least 60/75 °C must be used for wiring the module.

The maximum length of the encoder and motor cables is 30 m.

CAUTION



The S-DIAS module CANNOT be connected/disconnected while voltage is applied!

10 Description of Functions

10.1 Stepper Motor Output Stage Operating Modes

10.1.1 Full Step Mode

In full step mode, Current is applied to the winding as shown below. The motor rotates in full steps only. This means that in one turn the rated number of steps is taken.

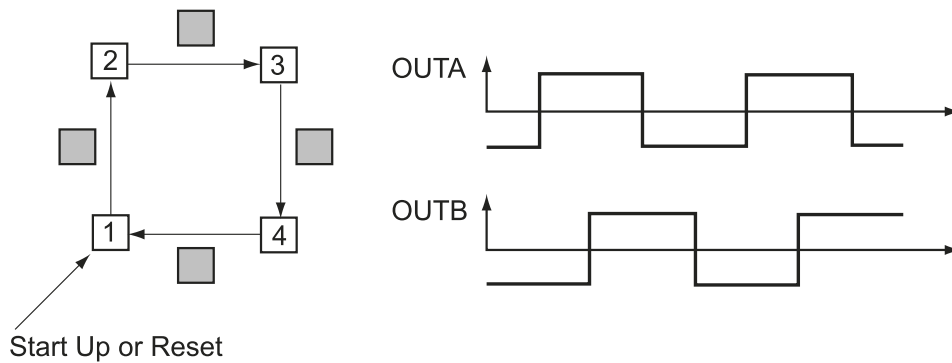

10.1.2 Half Step Mode

In half step mode, Current is applied to the winding as shown below. Between each full step, an intermediate step is taken. The resolution per turn is thereby doubled. In half step mode, a current increase can be activated by the software to reach 95 % of the full step torque.

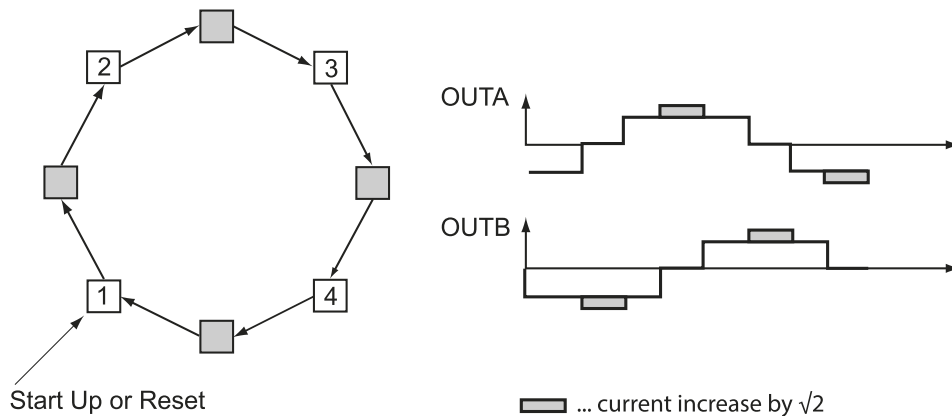

10.1.3 Micro Step Mode

In micro step mode, a nearly sine wave formed current is applied to the individual windings. With the ST 151(-X), the resolution of the sine oscillation is 256 steps. 64 micro steps per full step are thereby produced.

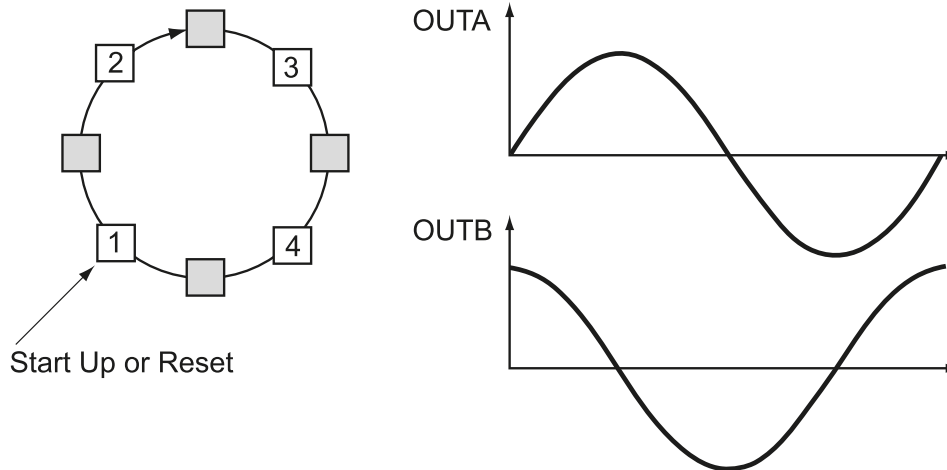

10.2 Stepper Motor Current Regulator

The current regulation for the stepper motor is influenced by the current rise and/or fall time in the motor windings. These times are critically dependent on the supply voltage level, inductivity and the resistance of the motor windings.

The current rise time can be influenced by the supply voltage level. The higher the supply voltage, the faster the motor winding current rises.

The current regulator functions so that the H-bridge actively energizes the motor windings until the value setting of the current (I_{TRIP}) is reached. Afterwards, the current reduction process (decay) is started. The current fall time in the motor windings is affected by the decay mode.

In slow decay mode, the motor windings are shorted over the H-bridge. The energy stored in the windings is dissipated over the internal resistance of the motor and the H-bridge of the output stage.

In fast decay mode, the current sinks significantly faster since the windings are shorted by reversing the polarity. The energy stored in the windings is thereby fed back to the supply.

If both variants are used during reduction of the motor current, the motor is in mixed decay mode. In this mode, the advantages of both processes are unified. The current is first reduced to a threshold with fast decay and then switched to slow decay to keep the current ripple low.

The ST 151(-X) has an adaptive fast decay current controller, by which the optimal decay mode is automatically used. Using the time required to reach the preset current value and the configured ChopperOnTimeMin (T_{ONMIN}) value, the current controller decides which decay mode is used and whether FastDecayTime (T_{FD}) is reduced, increased or maintained. The ChopperOnTimeMin, maximum FastDecayTime and maximum FastDecayTimeFallingStep for negative current value jumps can be configured via parameters. With the ChopperOffTime ($T_{CHOPPEROFF}$) parameter, the current controller base frequency is defined.

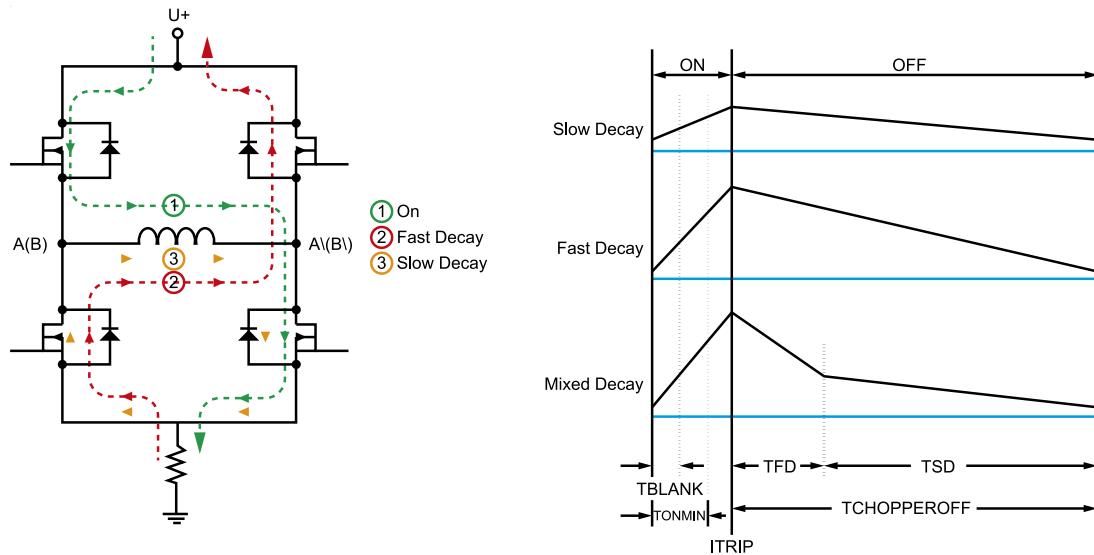

When the motor windings are switched over the H-bridge, parasitic capacitances generate current spikes during charging/discharging. For this reason, the current measurement is deactivated for a constant time (Blanking Time T_{BLANK}).

10.2.1 Signal Process “Count UP”

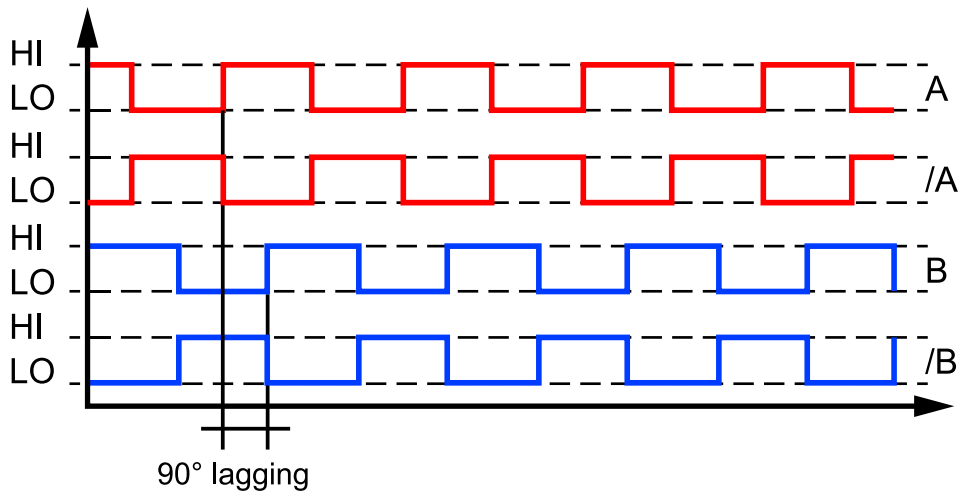

10.2.2 Signal Process “Count DOWN”

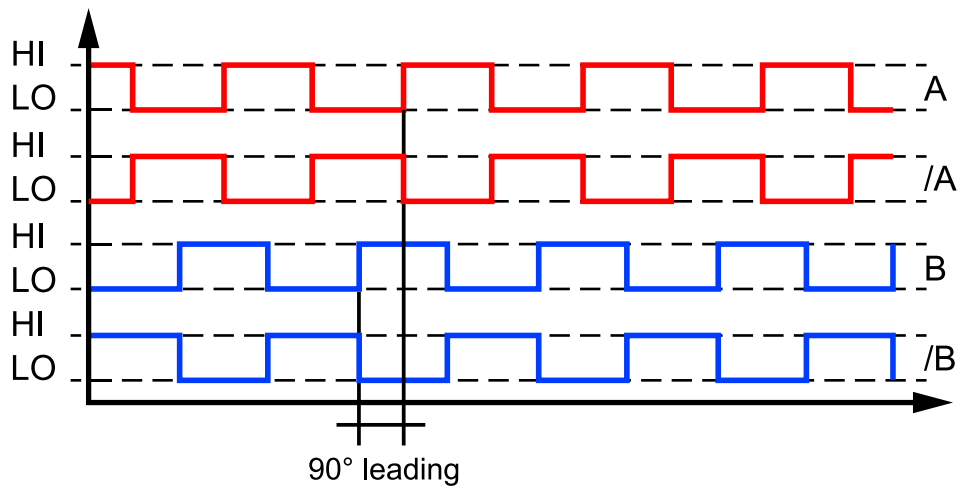

10.2.3 Signal Process “Reference impulse (Zero Position)”

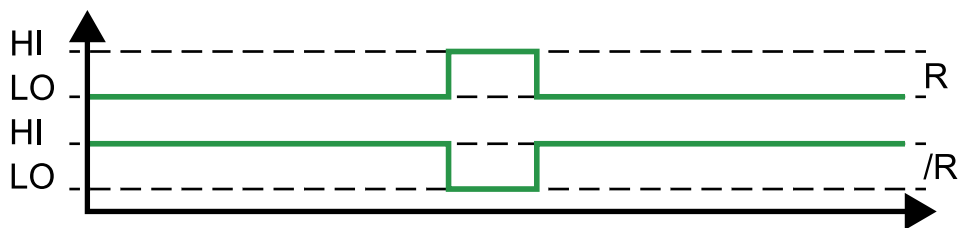

10.2.4 Latch Function

This function is primarily used for the reference motion. The incremental encoder data and frequency counter values can be stored (latched) in a selected input at the time of an event. The event source (input) and event type (edge) can be set via latch registers.

11 Additional Safety Information

The Safety function “STO” is an integrated part of the . It meets all necessary requirements for safe operation in SIL 3 according to EN IEC 62061 and in compliance with PL e. Cat. 4 in accordance with EN ISO 13849-1.

CAUTION



The instructions contained in this document must be followed.

- The ST 151(-X) can only be powered by supplies that meet the requirements for SELV or PELV in compliance with EN 60204.
For error-free operation, proper transport and storage are essential. See chapter 14 Transport/Storage.
- Installation, mounting, programming, initial start-up, operation, maintenance and decommissioning can only be performed by qualified personnel.
- Qualified personnel in this context are people, who have completed training or have trained under supervision of qualified personnel and have been authorized to operate and maintain safety-related equipment, systems and facilities in compliance with the strict guidelines and standards of safety technology.

ATTENTION



Les instructions contenues dans ce document doivent être suivies.

- Pour un fonctionnement sans erreur, le transport et le stockage appropriés sont essentiels. Voir le chapitre 13 pour plus d'informations.
- L'installation, le montage, la programmation, la mise en service initiale, l'exploitation, la maintenance et la mise hors service ne peuvent être effectués que par une personne qualifiée.
- Dans ce contexte, on entend par personnel qualifié les personnes qui ont suivi une formation ou qui ont été formées sous la supervision d'un personnel qualifié et qui ont été autorisées à utiliser et à entretenir l'équipement, les systèmes et les installations de sécurité conformément aux directives et aux normes strictes de la technique de sécurité.

CAUTION

For your own safety and that of others, the safety modules should be used for their designated purpose only.

Non-designated use consists of:

- any changes made to the safety module or the use of damaged safety modules.
- any changes made to the module or the use of damaged modules.
- use of the module inconsistent with the technical margins described in this manual or the specification's defined in the technical data (see chapter 6 Technical Data).

The main power supply for the servo amplifier must be disconnected using the main switch for the following instances:

- Cleaning, maintenance or repairs
- Extended still-stand periods

The module has no motor overtemperature monitoring/motor overtemperature cut-off.

CAUTION

Pour votre propre sécurité et celle des autres, les modules de sécurité ne doivent être utilisés qu'à des fins prévues. Correct EMC installation is also included in the designated use. Une installation CEM correcte est également incluse dans l'utilisation prévue.

L'utilisation non désignée consiste en:

- toute modification apportée au module ou l'utilisation des modules endommagés.
- use of the module inconsistent with the technical margins described in this manual or the specification's defined in the technical data (see chapter 6 Technical Data). utilisation du module non conforme aux marges techniques décrites dans ce manuel ou aux spécifications définies dans les données techniques (voir chapitre 6).

L'alimentation principale du variateur doit être débranchée à l'aide de l'interrupteur principal dans les cas suivants:

- Nettoyage, entretien ou réparation
- périodes d'immobilisation prolongées

Le module n'est pas équipé d'un système de surveillance de la surchauffe du moteur ni d'un système de coupure de la surchauffe du moteur.

DANGER

Failure to follow the above safety measures can lead to severe injuries.

- Only trained personnel are authorized to install the "safe restart lock" STO (Safe Torque off) and set the parameters.
- All control devices (switches, relays, PLC, etc.) and the control cabinet must meet the requirements for EN ISO 13849.
This includes:
 - Door switches, etc. with at least IP54 protection.
 - Control cabinet with at least IP54 protection.
- The proper cables and end-sleeves must be used.
- All cables that affect safety (e.g. control cables for the ENABLE 1 and ENABLE 2 inputs) must be laid in a cable duct outside of the control cabinet: Short or crossed circuits in the signal lines must be avoided! See EN ISO 13849.

If external forces influence axes that are used with the STO safety function (e.g. hanging load), additional measures must be taken (such as an electromagnetic double-surface spring brake, instead of a permanent magnet brake).

DANGER

Le non-respect des mesures de sécurité ci-dessus peut entraîner des blessures graves.

- Seul un personnel qualifié est autorisé à installer le "blocage de redémarrage sûr" STO (Safe Torque off) et à régler les paramètres.
- Tous les appareils de commande (interrupteurs, relais, API, etc.) et l'armoire de commande doivent satisfaire aux exigences de la norme EN ISO 13849.
Il s'agit des éléments suivants :
 - interrupteurs de porte, etc. avec une protection d'au moins IP54
 - armoire de commande avec une protection d'au moins IP54.
- Les câbles et les embouts appropriés doivent être utilisés.
- Tous les câbles affectant la sécurité (par ex. les câbles de commande pour les entrées ENABLE 1 et ENABLE 2) doivent être posés dans un conduit de câbles de raccordement à l'extérieur de l'armoire électrique. Éviter les courts-circuits ou les courts-circuits croisés dans les lignes de signalisation! Voir EN ISO 13849.

Si des forces externes influencent les axes utilisés avec la fonction de sécurité STO (par ex. charge suspendue), des mesures supplémentaires doivent être prises (par ex. un frein à ressort électromagnétique à double surface au lieu d'un frein à aimant permanent).

WARNING



Hot surface warning!

Physical contact poses a burn hazard!

With unfavorable installation and operating conditions, the surface of the S-DIAS drive module can reach temperatures up to 84 °C and remain hot for some time after operation.

Avertissement de surface chaude !

Le contact physique présente un risque de brûlure !

En cas de conditions d'installation et de fonctionnement défavorables, la surface du module d'entraînement S-DIAS peut atteindre des températures allant jusqu'à 84 °C et rester chaude pendant un certain temps après utilisation.

11.1 STO

The ST 151(-X) supports the safety functions STO (Safe Torque Off) and meets the requirements for Category 4 Performance Level "e" according to EN ISO 13849-1 and SIL 3 according to EN IEC 62061.

For his purpose, the servo amplifier has two safe inputs ENABLE 1 and ENABLE 2.

Only PELV/SELV power supply units may be used as the +24 V power supply.

11.2 Function

The safety functions in the ST 151(-X) are controlled over two digital inputs.

The following table shows the status that the ENABLE 1 and ENABLE 2 inputs must assume to enable normal operation or trigger the safety function.

Input Status		Description
ENABLE 1	ENABLE 2	
Open	Open	Safe status of the drive system
Open	Low	
Low	Open	
Low	Low	
High	High	Drive system ready

If the ENABLE 1 and ENABLE 2 are changed from any status to the "Drive Ready" status, the servo amplifier is not immediately enabled. In order to set the system to the status "Drive system ready", a change from "Low-Low" to "High-High" has to be executed. The reason for this is that, for example, sticky contacts of switching devices are detected.

11.3 Function Test

The safety function test is required to ensure correct operation. The entire safety circuit must be tested for full functionality.

Tests must be performed at the following times:

- After installation
- In regular intervals, or at least once a year

WARNING



If the function test results in an invalid machine status, the error must be found and corrected before the safety function is retested. If the error reoccurs during the function test, the machine can no longer be operated.

Si le test de fonctionnement aboutit à un état machine non valide, l'erreur doit être détectée et corrigée avant que la fonction de sécurité ne soit de nouveau testée. Si l'erreur se reproduit pendant le test de fonctionnement, la machine ne peut plus être utilisée.

12 Wiring Examples

In the following sub chapters, wiring examples are provided. It must be ensured that all constructive measures etc. are complied with and applied in order to fulfill the requirements of the category used.

12.1 Performance Level e, Category 4 or SIL 3 - Safety PLC

To meet the requirements of category 4, performance Level "e" for EN ISO 13849-1 and SIL 3 according to EN IEC 62061, two error-proof output of a Safety PLC must be used. Cross-circuit detection between the two lines via the output tests of the STO 081 is hereby possible.

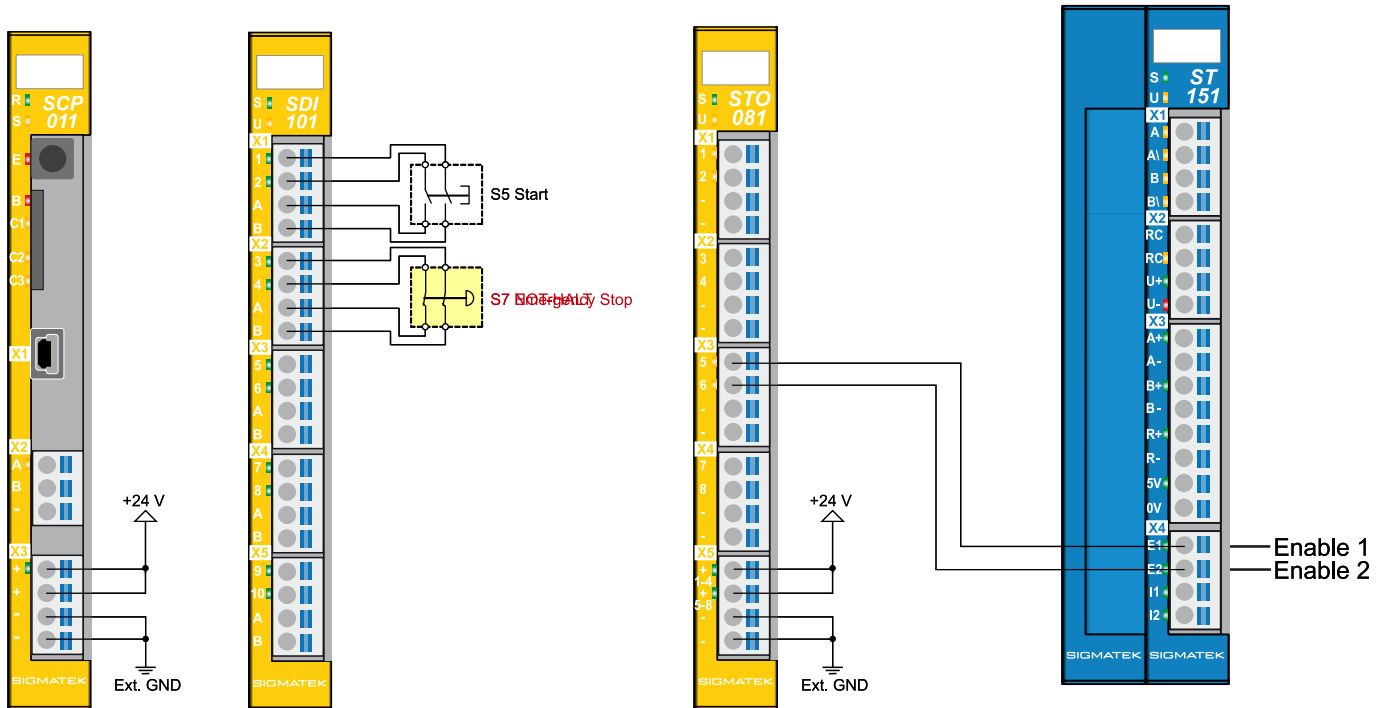

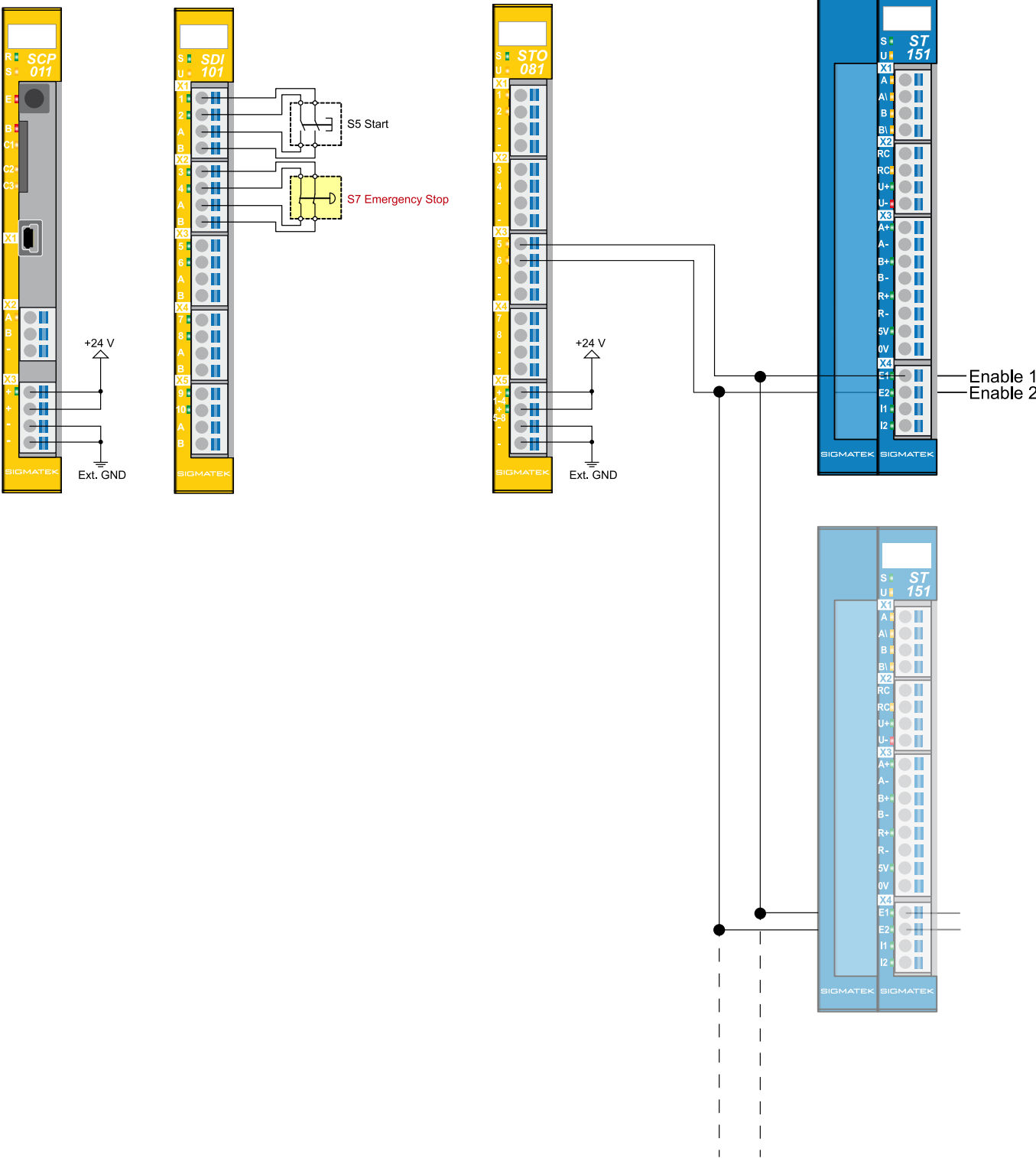

12.2 Performance Level e, Category 3 or SIL 3 - Safety PLC

To meet the requirements of safety category 3, performance level "e" for EN ISO 13849-1 and SIL 3 according to EN IEC 62061, an error-proof output of a safety PLC must be used. The reason of category 3 here, is that cross-circuit detection between the two lines is not possible.

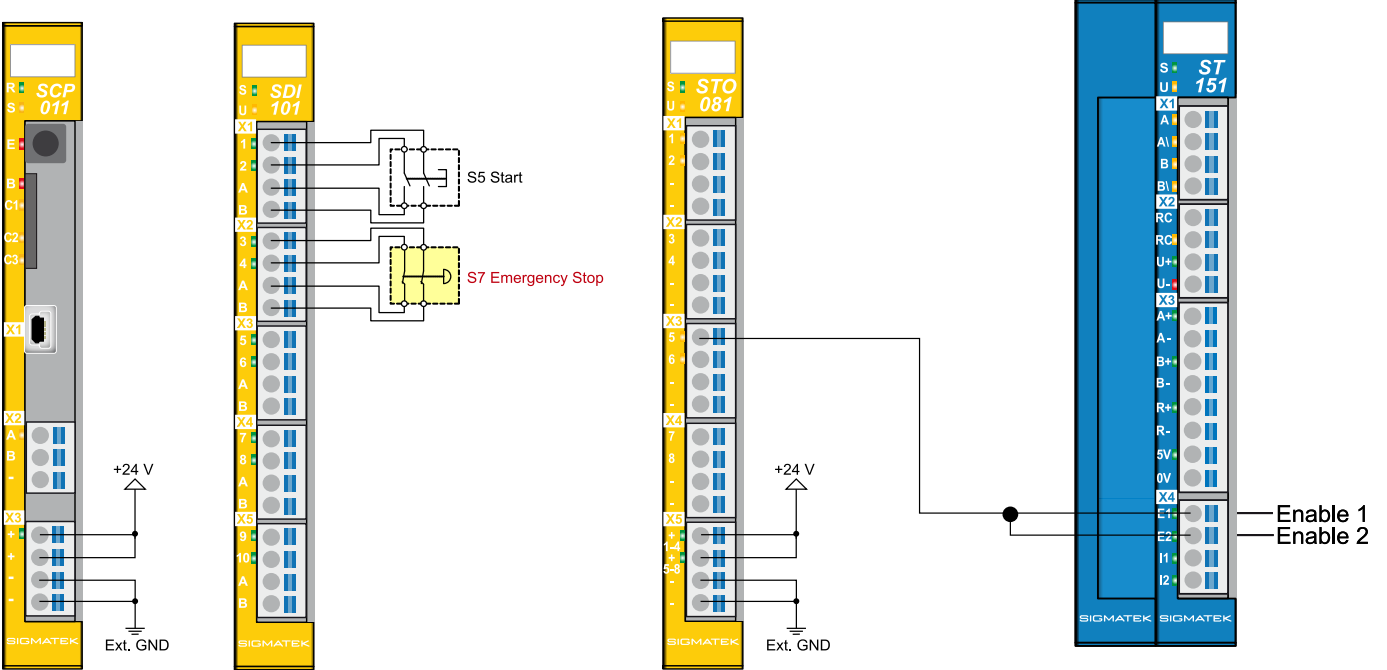

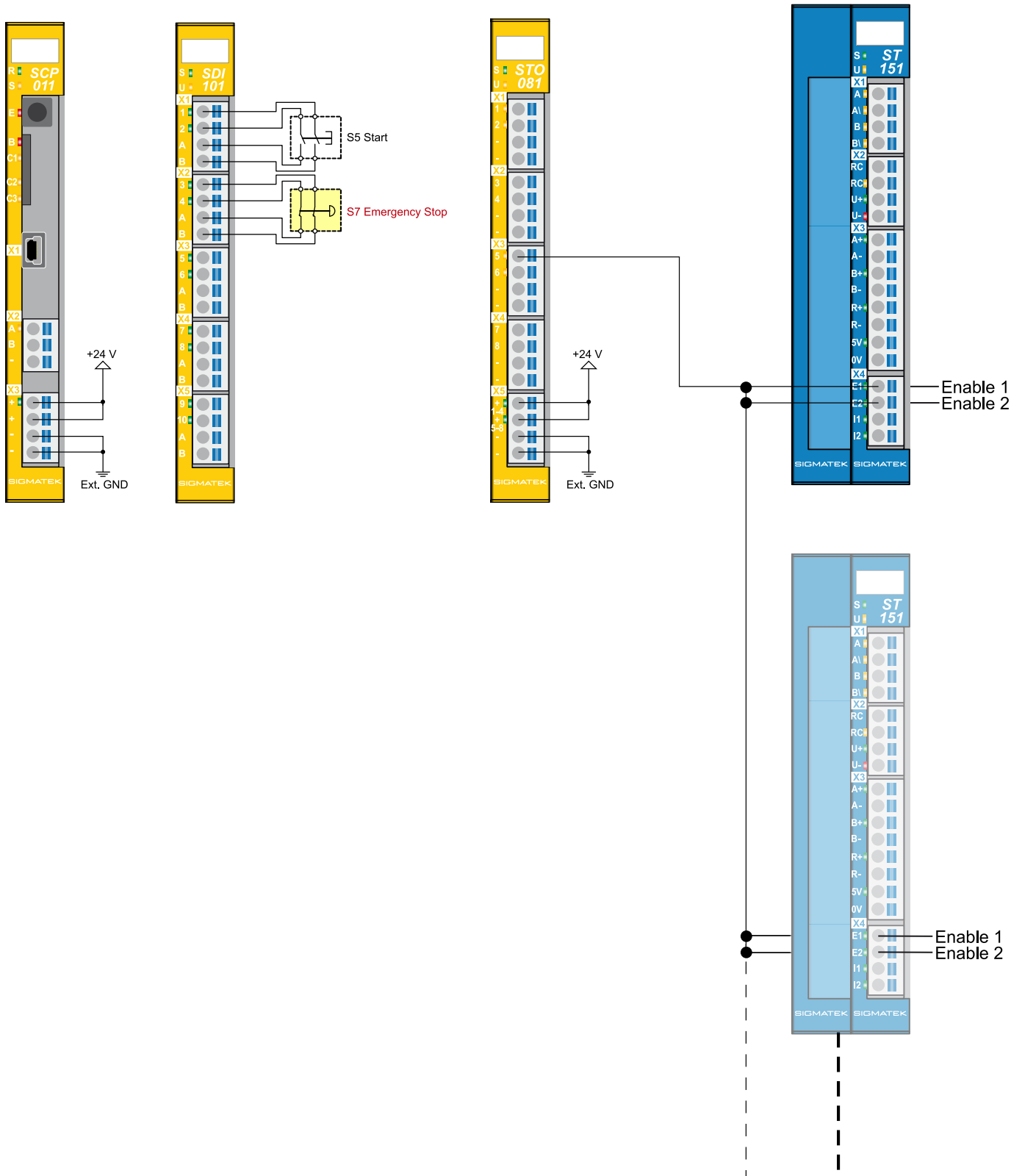

12.3 Performance Level e, Category 4 or SIL 3 - Conventional

To meet the requirements of safety category 4, performance level "e" for EN ISO 13849-1 and SIL 3 according to EN IEC 62061, the placement of the lines must comply with EN ISO 13849-2, table D.4 (separate placement, prohibiting of error via short circuits between wires) as cross-circuit detection is not possible here.

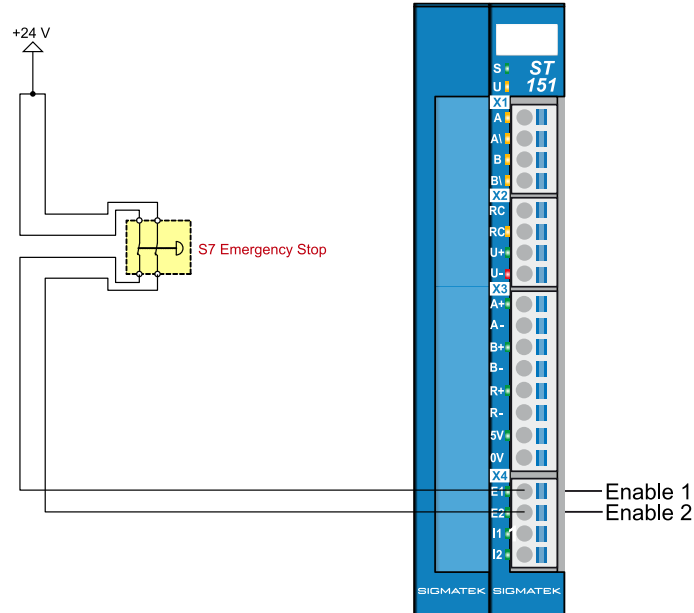

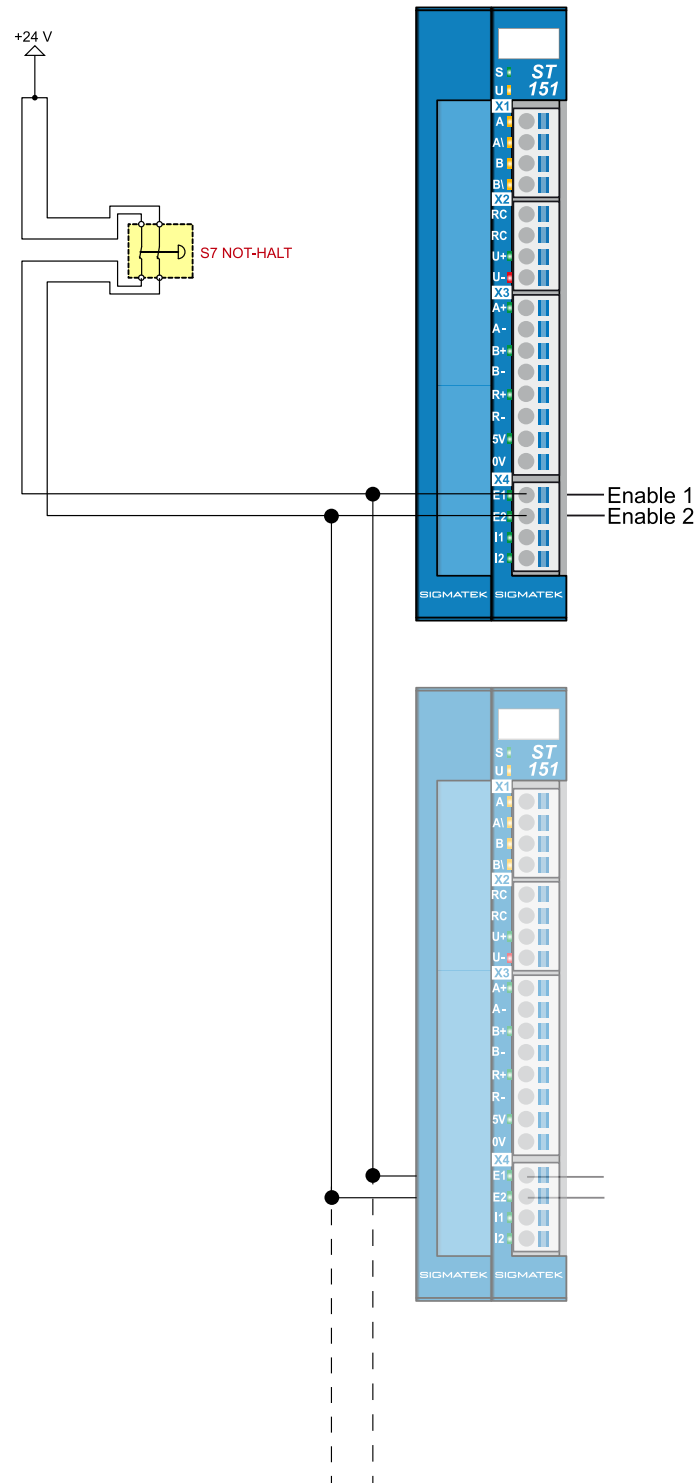

12.4 Performance Level e, Category 2 or SIL 2 - Conventional

This involves 1-channel wiring, whereby the Enable inputs are tested separately. Here, no cross-circuit detection is possible.

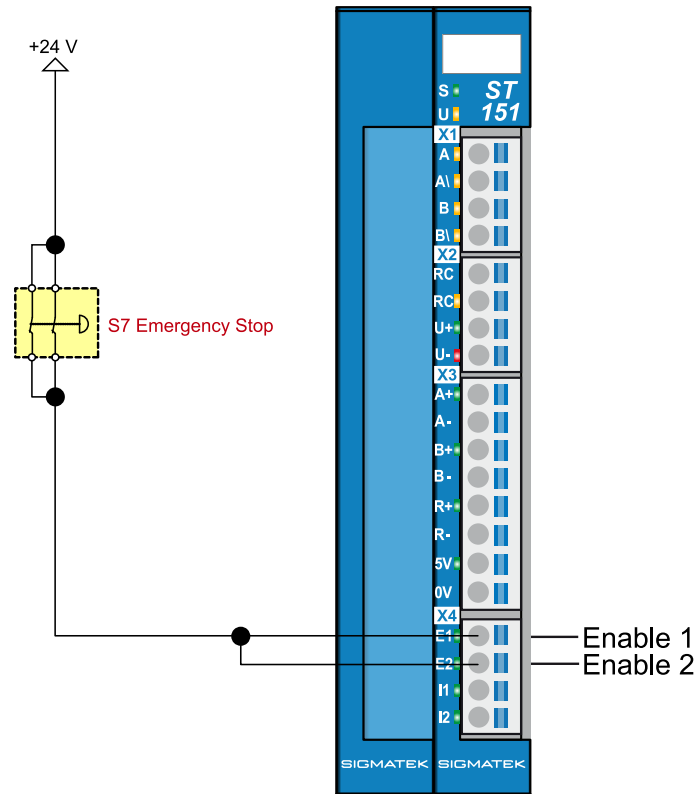

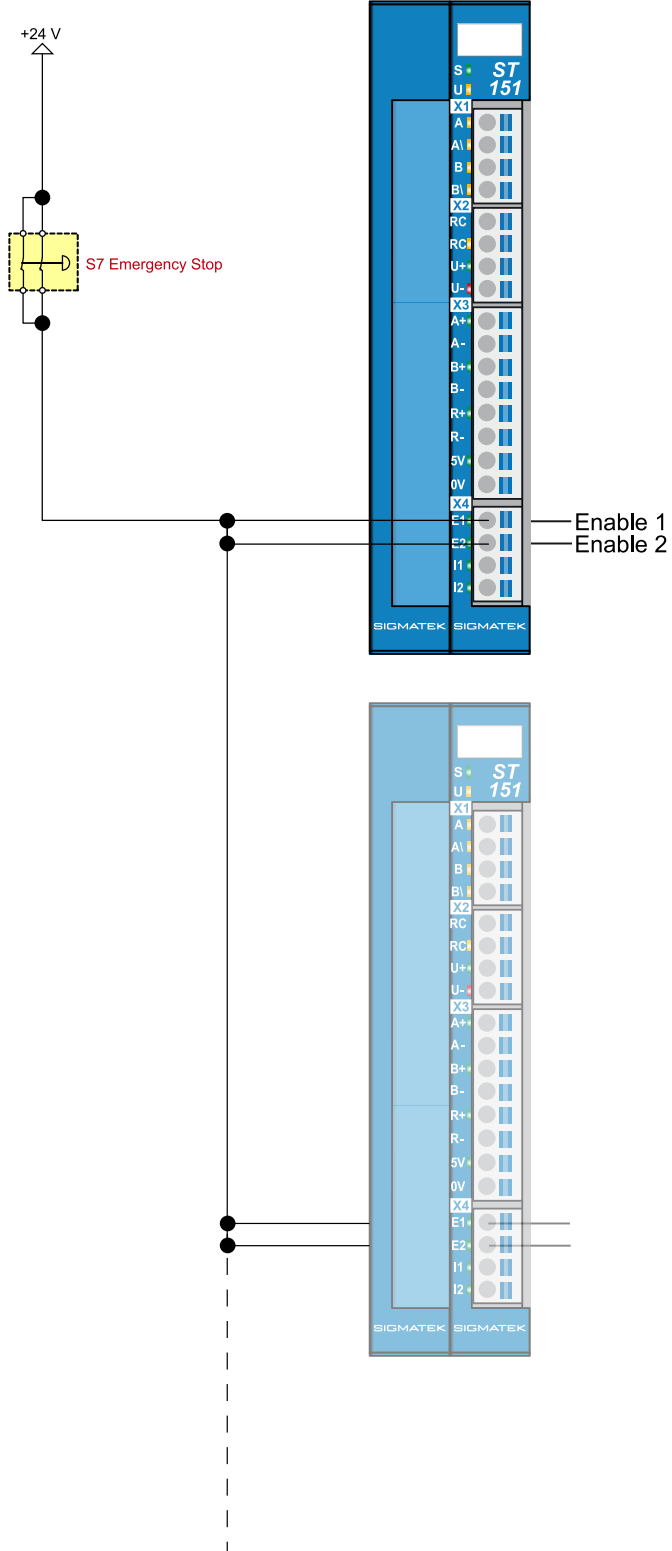

13 Assembly/Installation

13.1 Check Contents of Delivery

Ensure that the contents of the delivery are complete and intact. See chapter 1.3 Contents of Delivery.

INFORMATION



On receipt and before initial use, check the device for damage. If the device is damaged, contact our customer service and do not install the device in your system.

Damaged components can disrupt or damage the system.

13.2 Mounting

The S-DIAS modules are designed for installation into the control cabinet. To mount the modules, a DIN-rail is required. The DIN rail must establish a conductive connection with the back wall of the control cabinet. The individual S-DIAS modules are mounted on the DIN rail as a block and secured with latches. The functional ground connection from the module to the DIN rail is made via the grounding lug on the back of the S-DIAS modules. The modules must be mounted horizontally (module label up) with sufficient clearance between the ventilation slots of the S-DIAS module blocks and nearby components and/or the control cabinet wall. This is necessary for optimal cooling and air circulation to ensure proper function up to the maximum operating temperature.

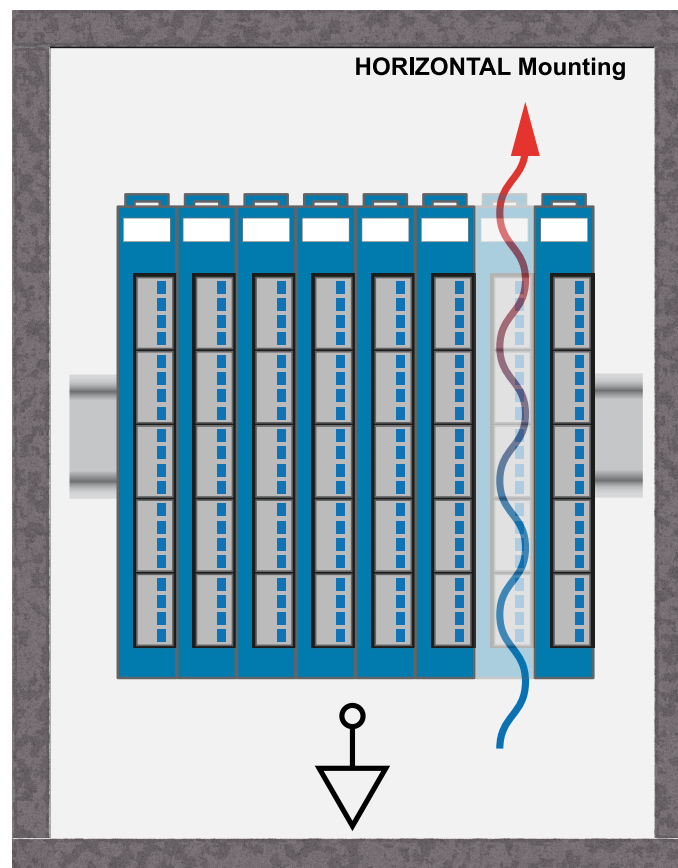

Recommended minimum distances between the S-DIAS modules and the surrounding components or control cabinet wall:

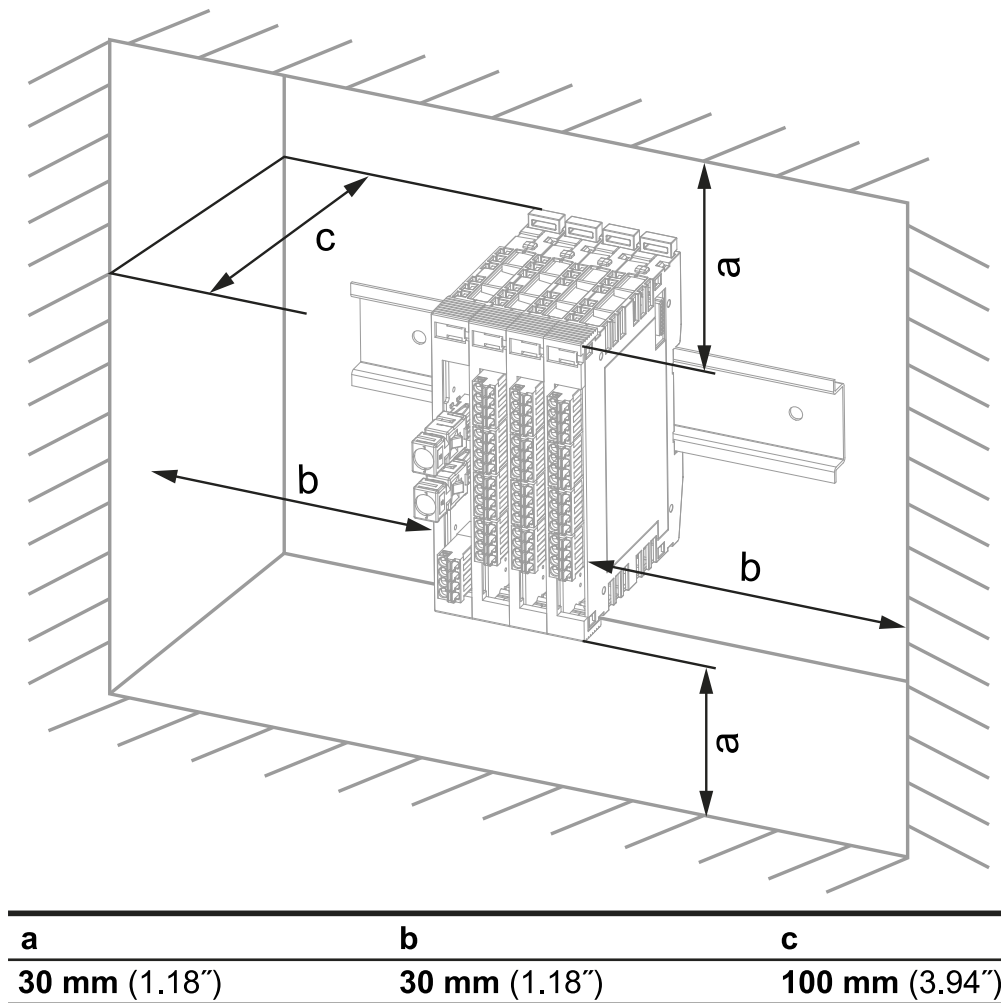

a, b, c ... distances in mm (inches)

14 Transport/Storage

This device contains sensitive electronics. During transport and storage, high mechanical stress must therefore be avoided.

For storage and transport, the same values for humidity and vibration as for operation must be maintained!

Temperature and humidity fluctuations may occur during transport. Ensure that no moisture condenses in or on the device, by allowing the device to acclimate to the room temperature while turned off.

When sent, the device should be transported in the original packaging if possible. Otherwise, packaging should be selected that sufficiently protects the product from external mechanical influences. Such as cardboard filled with air cushioning.

15 Storage

When not in use, store the device according to the storage conditions. See chapter 14 Transport/Storage.

INFORMATION



During storage, ensure that all protective covers (if available) are placed correctly, so that no contamination, foreign bodies or fluids enter the device.

16 Maintenance

During maintenance as well as servicing, observe the safety instructions from chapter 2 Basic Safety Directives.

16.1 Service

This product was constructed for low-maintenance operation.

16.2 Repair

In the event of a defect/repair, send the device with a detailed error description to the address listed at the beginning of this document.

For transport conditions, see chapter 14 Transport/Storage.

17 Disposal

INFORMATION



Should you need to dispose of the device, the national regulations for disposal must be followed.

The device appliance must not be disposed of as household waste.



Changes Chart

Change date	Affected page(s)	Chapter	Note
05.02.2018	15	6.1 Stepper Motor Output Specification	Expansion and Edit
18.06.2018	18	6.6 Electrical Requirements	Notes updated
02.04.2019	13	4.4 Safety-Relevant Parameters	Correction of the safety-relevant parameters
	20	6.8 Environmental Conditions	Corrections environmental conditions
	all		Corrections due to CE
29.07.2019	23	8.1 Status LEDs	Enable input corrected
02.12.2019	13	4.4 Safety-Relevant Parameters	Values updated
28.04.2020	23	8.1 Status LEDs	Corrected under Motor Error Enable input
06.08.2020	18	6.6 Electrical Requirements	Current consumption of the +24 V supply on the S-DIAS bus changed to typically 80 mA maximum 120 mA
08.09.2020	42	15 Hardware Class ST 151(-X)	Chapter added
04.11.2020	45	13 Assembly/Installation	Expansion functional ground connection
10.12.2020	23	8.1 Status LEDs	Motor error "red blinks" changed to "red on"
01.06.2021	20	6.7 Miscellaneous	20-014-151-X added
01.07.2021	17	6.3 Incremental Encoder Input Specifications	Integrated in module
17.09.2021	18	6.6 Electrical Requirements	Note for cable lengths added
14.07.2023	18	6.6 Electrical Requirements	NEC Class 2 note removed
05.12.2023	5	1 Introduction	ST 151(-X) added
	20	6.7 Miscellaneous	Mission time and Reaction time added
	20	6.8 Environmental Conditions	Noise emissions added
		15 Hardware Class ST 151(-X)	Chapter deleted
01.02.2024	13	4.3.2 EU Declaration of Conformity	Download instructions adapted
01.02.2024	13	4.4 Safety-Relevant Parameters	The safety indicators (PFH, MTTFD) were adjusted slightly with the recertification.
14.02.2024	13	4.4 Safety-Relevant Parameters	The safety indicators (PFH, MTTFD) were adjusted slightly with the recertification.
19.02.2024	27	9.2 Note	Info text extended
	32	11 Additional Safety Information	Precautionary measures added
21.02.2024			Short name (-X) adjusted
	11	3 IT Security	Chapter added
01.03.2024	20	6.8 Environmental Conditions	UL certification information added

Change date	Affected page(s)	Chapter	Note
21.01.2026	17	6.4 Latch/Digital Inputs Specifications	Signal level changed